

***JM Aerofoil
H.T. Series Fan 50Hz
Smoke Venting Equipment***



AIRTREND Ltd.
Predstavništvo u Beogradu
Kumanovska 14, 11000 Beograd
Tel: 011/3836886, 3085740
Faks: 011/3444113
e-mail: gobrid@eunet.rs
web: www.airtrend.rs

FläktWoods

Contents

	Page:
Introduction	4
Applications & Performance Testing	5
Specification	6
Guide to Fan Selection	7
Performance	8
Motor Frame Size Schedules -	
H.T. Temperature / Time Categories	
H.T. 250/2 & 300/0.5	9-12
H.T. 300/1 - Single Speed	13-16
H.T. 300/1 - Two Speed	17-23
H.T. 400/2 - Single Speed	24-26
H.T. 400/2 - Two Speed	27-30
Dimensions & Weights	
Ancillaries	

Introduction

Woods Air Movement Limited, has made Aerofoil axial flow fans suitable for continuous operation in high temperature air streams for over 30 years. These fans are currently fitted into Drying Machines, Stenters, and Smoke Venting systems, all over the world.

This long experience coupled with the introduction of the new improved performance JM Aerofoil fan range forms the basis for the new H.T. SERIES fans and roof extract units designed specifically for Fire Smoke Ventilation.

Woods manufactures fan motors, and is therefore able to look critically at the requirements of motor insulation, bearings and lubricants which are vital elements in achieving high temperature performance. Extensive stress tests on the new JM Aerofoil fan impellers operating at high temperatures has enabled Woods to make the best use of both designs and materials.

A full high temperature test programme has been successfully completed. Some of this programme was carried out at independent laboratories, eg T.Ü. in Germany and C.T.I.C.M. in France

These tests combined with Woods' renowned high standard of engineering and quality assurance serve to support the H.T. SERIES specification.

Extensive market research has resulted in the H.T. SERIES being offered in six temperature/time categories to meet all of the internationally recognised requirements.

The equipment detailed in this publication is not the full range of items available. If your requirement is not included please enquire to your nearest sales office.

TEMPERATURE (°C)	TIME (Hours)	CATEGORY CODE	FAN TYPES* AVAILABLE	ROOF EXTRACT** UNITS AVAILABLE
200	2.0	H.T.200/2	AEROFOIL	DVA & UDA
250	2.0	H.T.300/0.5	AEROFOIL	DVA & UDA
300	0.5			
300	1.0	H.T.300/1.0	AEROFOIL	DVA & UDA
400	2.0	H.T.400/2	AEROFOIL	UDA
600**	1.5	H.T.600/1.5B**	BIFURCATED	UDA

* Other fan types are available, e.g. Bifurcated and Varofoil - Please refer to separate publication C10.

** Refer to separate publication C10 for details of this specialist range of fans/units.

Applications & Performance Testing

In any building, fire smoke can be the major killer. In the event of fire in densely populated buildings, such as DEPARTMENT STORES, SHOPPING MALLS, SPORTS CENTRES and HOTELS, efficient clearance of smoke is vital to:

- Keep escape routes clear at all times.
- Assist fire brigades in fighting fire.
- Minimise damage to buildings and contents.

Woods H.T. SERIES smoke venting fans and roof extract units achieve this using simple designs and tested and certified components.

All H.T. SERIES fans and roof extract units, are suitable for continuous operation at temperatures up to 50°C max, and therefore can be used to provide the normal ventilation requirements of the building.



High temperature Aerofoil Test Rig.

Quality is assured at Woods. The H.T. SERIES is no exception, with compliance of Woods to BS EN ISO9001:1994, the international standard for Quality Assurance.

H.T. SERIES JM Aerofoil fans (and roof extract units) have successfully completed an extensive programme of high temperature tests from 200°C to 400°C for periods varying from half an hour to two hours, and would operate when tested in accordance with BS7346: Part 2: 1990.

Some of these tests have been witnessed by independent authorities such as the Loss Prevention Council (F.I.R.T.O.) in the U.K., or undertaken in independent laboratories at C.T.I.C.M. in France and Technische Universität (T.U.) München in Germany.



The H.T. SERIES fans are certified and approved for use in fire smoke venting systems. All performances shown are based on tests to ISO5801.

Specifications - Fans

JM Aerofoil Fans

Full technical data of the highly efficient Woods JM Aerofoil Fan range can be found in publications C22a and C23a.

Aerofoil fan motors are rated to handle the peak powers of the fans at both ambient and high temperature. JM Aerofoil fans have a safe non-overloading characteristic.

Casings

The cylindrical casing, housing the fan, is made of steel, hot dipped galvanised after manufacture. It is flanged and drilled at each end for ease of installation.

S-TYPE - The casing surrounds the impeller only and supports the motor mounting. The electrical terminal box is mounted on the motor. Suitable for temperatures up to 400°C.

L-TYPE - The casing completely surrounds both the impeller and motor. The terminal box is mounted on the casing and pre-wired to the motor. Suitable for temperatures up to 400°C.

Impellers

Fan categories H.T.250/2: H.T.300/0.5: H.T.300/1 and H.T.400/2 use a Woods JM Aerofoil impeller, die cast in aluminium alloy and X-ray inspected against exacting standards to ensure stable castings. Impellers have a range of blade angles and impeller solidity (number of blades) for flexibility of air duty. Impeller blade angles are set and fixed at works, but are adjustable on site within motor power limits.

Motors

Woods H.T. SERIES fans utilise a totally enclosed induction motor. The motor carcass is constructed of either aluminium alloy or cast iron dependent on the temperature of operation.

The grades of motor insulation have been selected to meet the specific requirements of each H.T. Category, as the essential property of withstanding thermal shock is not common to all high temperature materials. At temperatures above 400°C, bifurcated fans with motor out of the air stream are the only reliable solution. (See our publication C10). Two speed motors available.

Pole Change (PC)

or Dahlander

Two speeds can be obtained by reconnecting a single winding via six winding terminals to give two separate polarities. The term "Pole change" or "Dahlander" refers to polarity/speed ratios of 2 : 1.

Pole Amplitude Modulation (PAM)

This allows speed ratios other than 2 : 1 to be achieved. The motor winding is reconnected in the same way as for a pole change winding.

Dual Wound

This type of motor has two separate individual windings of the requisite polarity to give the speeds required.

Details of dual wound motors are available on request.

Lubrication

Woods H.T. SERIES fan motor bearings for time/temperature categories above H.T.200/2 must be lubricated strictly in accordance with the instructions on the motor nameplate.

The motor bearings and greases used in the H.T. SERIES have been selected to provide long life at normal ambient temperature and still survive the emergency condition during this life-time.

The special greases required for fan motors operating above 300°C are unsuitable for conventional relubricating methods - extended lubricators, grease guns etc. Here the motor will need to be dismantled and regreased at specified intervals.

Electrical Supplies

H.T. SERIES fans are available for connections to 380 - 420 V / 50 Hz / 3f electrical supplies. For other voltages and frequencies - please enquire.

L-Type JM Aerofoil Fan



S-Type JM Aerofoil Fan

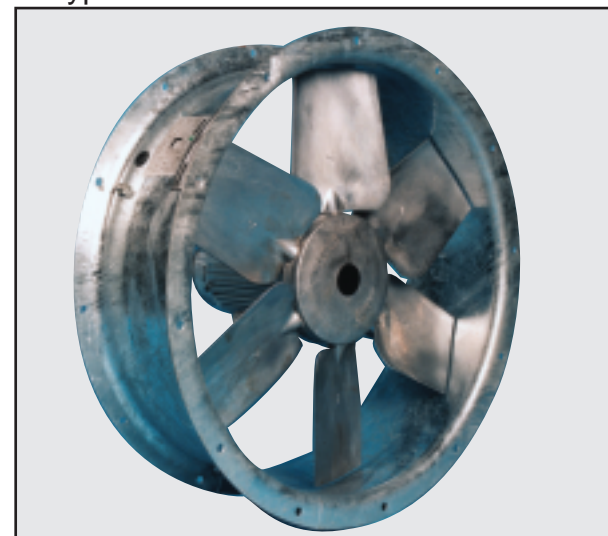

Guide to Fan Selection

Publication C10 details a selection of popular fans to be used for fire smoke venting. This is not the complete range. For details outside this range please enquire.

The detailed performance data is contained within publications JM/SS and C23a. These publications can be used to obtain fan selections with the associated impeller blade pitch angle data. For motor and electrical data, dedicated motor frame size schedules have been included for categories H.T.250/2 and 300/0.5 H.T.300/1 and H.T. 400/2 (see pages 9 to 30).

Once a fan has been selected from publication JM/SS or C23a, use the relevant motor frame size schedule to select the required motor.

NOTES:

1) No performance corrections are necessary for an H.T. categories up to and including H.T.200/2 or when any H.T. fan is to be used for emergency ventilation only. If fans are to be used for H.T. Category 250/2; 300/0.5 or 300/0 for both normal and emergency duty applications, increase the required static pressure by 10% prior to selection. If the fans are to be used for both normal and emergency duty applications at H.T. Category 400/2, this correction should be 20%.

2) For exhaust volumes greater than those provided by 100 JM use Woods H.T. Series - J Range publication.

Examples:

For a required duty of $8\text{m}^3/\text{sec}$ @ 200 Pa fan static pressure:

H.T. Category H.T. 200/2

Aerodynamic Selection - use publications JM/SS or C23a: 80JM/25/4/6/28°

Motor Data - Use publications JM/SS or C23a (i.e. standard motor data applies - single phase motors are not suitable)

F2249

Motor Rating (kW) = 4.4
Full load current (A) = 9.3
Starting Current (A) = 52

H.T. Category H.T. 250/2 & H.T. 300/0.5

Aerodynamic selection - Use publications JM/SS or C23a: 80JM/25/4/6/28°

Motor data - Use dedicated motor frame size schedule (Pages 9 to 12 enclosed).

D132/MS

Motor Rating (kW) = 6.3
Full load current (A) = 13.1
Starting Current (A) = 85

H.T. Category H.T. 300/1

Aerodynamic selection - Use publications JM/SS or C23a: 80JM/25/4/6/28°

Motor data - Use dedicated motor frame size schedule (Pages 13 to 23 enclosed).

D112M

Motor Rating (kW) = 4.6
Full load current (A) = 9.8
Starting Current (A) = 58.8

H.T. Category H.T. 400/2

Only if the fan is to be used for both normal and emergency duty applications, increase required static pressure by 20%
= $200 \times 1.2 = 240$ Pa

New duty for selection purposes = $8\text{m}^3/\text{sec}$ @ 240 Pa fan static pressure.

Aerodynamic Selection - Use publications JM/SS or C23a: 80JM/25/4/6/30°

Motor data - Use dedicated motor frame size schedule (Pages 24 to 30 enclosed)

DF132MS

Motor Rating (kW) = 5.5
Full load current (A) = 11.1
Starting current (A) = 76

Please enquire if alternative temperature time categories are required.

H.T. Category H.T. 600/1.5

For this particular H.T. Category please enquire or refer to publication C10.

Performance

Time Category H.T. 250/2 ; H.T. 300/0.5 & H.T. 300/1

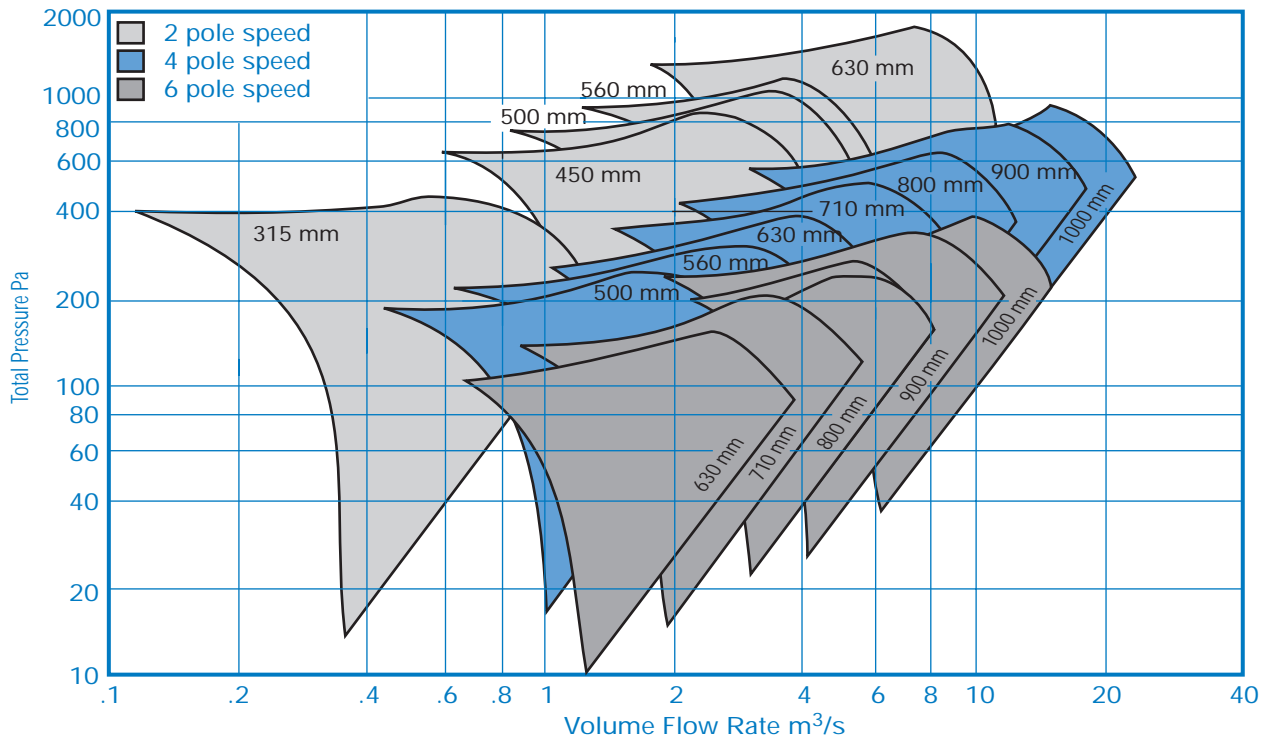

Time Category H.T. 400/2

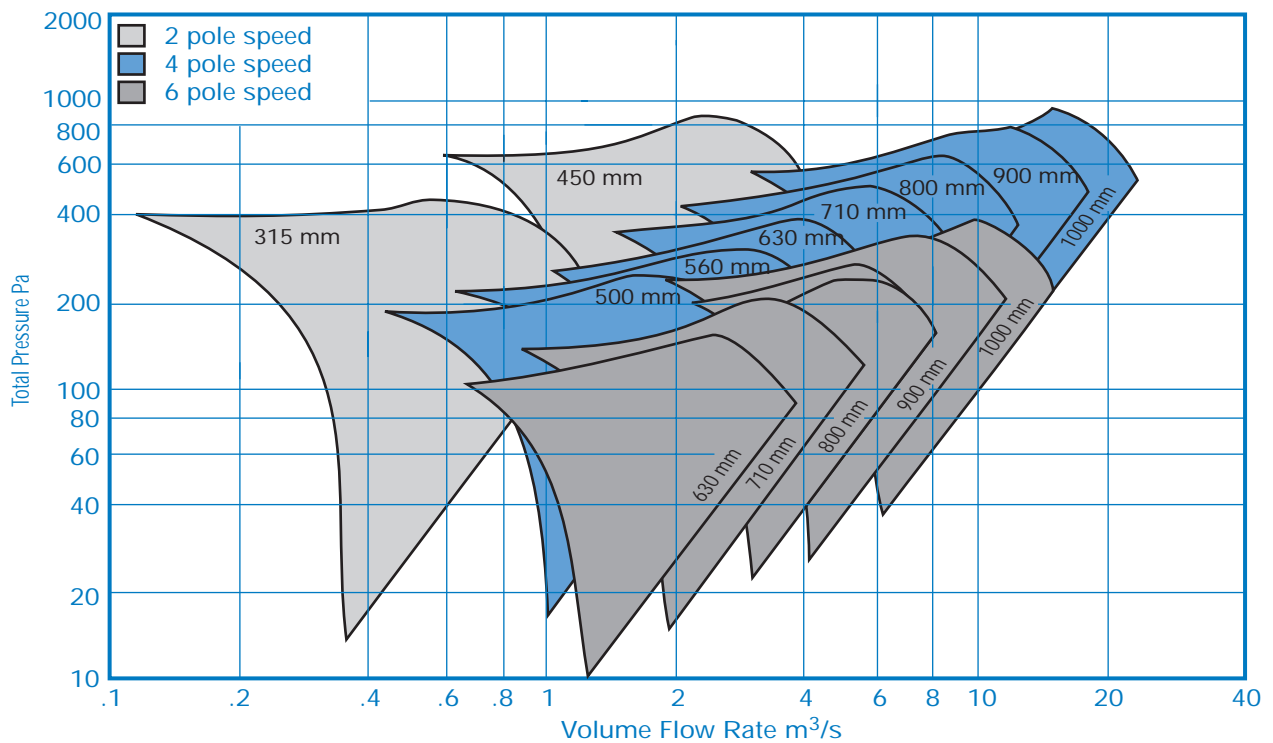

JM AEROFOIL - H.T. SERIES



Motor Frame Size Schedules: H.T. 250/2 & H.T. 300/0.5

400 V / 50 Hz / 3 ϕ

Code	Speed rev/min	Max. Pitch Angle (°)	Motor	Motor Rating (kW)	Full Load Current (A)	Starting Current d.o.l (A)	Efficiency %	Power Factor cos ϕ
63JM/25/4/3/...	1440	32	F2245B	2.5	5.7	30	83	0.8
63JM/25/2/3/...	2910	14	F2225B	3.3	7	44	79	0.87
		20	F2229B	5.7	11.5	90	85	0.86
		22	DF132/MSA	6.3	12	84	86	0.88
		28	DF132/MSB	8.6	16.3	114	86	0.88
		32	DF132/M	12	22	165	88	0.9
63JM/25/6/6/...	935	36	F2265B	1.4	4	15	73	0.7
63JM/25/4/6/...	1440	36	F2245B	2.5	5.7	30	83	0.8
63JM/25/2/6/...	2910	8	F2225B	3.3	7	44	79	0.87
		14	F2229B	5.7	11.5	90	85	0.86
		16	DF132/MSA	6.3	12	84	86	0.88
		20	DF132/MSB	8.6	16.3	114	86	0.88
		26	DF132/M	12	22	165	88	0.9
		26	DF160/LMA	12.6	24	180	87	0.87
		34	DF160/LMB	17.3	32	240	88	0.89
		36	DF160/L	22	38	285	90	0.91
63JM/25/6/9/...	935	40	F2265B	1.4	4	15	73	0.7
63JM/25/4/9/...	1440	32	F2245B	2.5	5.7	30	83	0.8
		40	F2249B	4.2	9	52	82	0.84
63JM/25/2/9/...	2910	10	F2229B	5.7	11.5	90	85	0.86
		12	DF132/MSA	6.3	12	84	86	0.88
		16	DF132/MSB	8.6	16.3	114	86	0.88
		22	DF132/M	12	22	165	88	0.9
		22	DF160/LMA	12.6	24	180	87	0.87
		28	DF160/LMB	17.3	32	240	88	0.89
		34	DF160/L	22	38	285	90	0.91
		40	DF160/LKE	30	53	398	90	0.91
71JM/20/6/3/...	900	34	CT9	0.75	2.5	7.5	63	0.7
		36	F2265B	1.4	4	15	73	0.7
71JM/20/4/3/...	1440	8	CT5	0.7	2	6.5	67	0.76
		20	CT9	1.3	3.3	12	72	0.79
		32	F2245B	2.5	5.7	30	83	0.8
		36	F2249B	4.2	9	52	82	0.84
71JM/20/6/6/...	900	24	CT9	0.75	2.5	7.5	63	0.7
		36	F2265B	1.4	4	15	73	0.7
71JM/20/4/6/...	1440	10	CT9	1.3	3.3	12	72	0.79
		22	F2245B	2.5	5.7	30	83	0.8
		34	F2249B	4.2	9	52	82	0.84
71JM/25/6/3/...	935	32	F2265B	1.4	4	15	73	0.7
71JM/25/4/3/...	1440	32	F2245B	2.5	5.7	30	83	0.8
71JM/25/6/6/...	935	36	F2265B	1.4	4	15	73	0.7
71JM/25/4/6/...	1440	26	F2245B	2.5	5.7	30	83	0.8
		36	F2249B	4.2	9	52	82	0.84
71JM/25/6/9/...	935	36	F2265B	1.4	4	15	73	0.7
71JM/25/4/9/...	1440	20	F2245B	2.5	5.7	30	83	0.8
		32	F2249B	4.2	9	52	82	0.84
		36	DF132/MS	6.3	13.1	85	85	0.81

JM AEROFOIL - H.T. SERIES



Motor Frame Size Schedules: H.T. 250/2 & H.T. 300/0.5

400 V / 50 Hz / 3 φ

Code	Speed rev/min	Max. Pitch Angle (°)	Motor	Motor Rating (kW)	Full Load Current (A)	Starting Current d.o.l (A)	Efficiency %	Power Factor cos Ø
80JM/20/6/3/...	935	24 36	CT9	0.75	2.5	7.5	63	0.7
			F2265B	1.4	4	15	73	0.7
80JM/20/4/3/...	1440	12 22 34	CT9	1.3	3.3	12	72	0.79
			F2245B	2.5	5.7	30	83	0.8
			F2249B	4.2	9	52	82	0.84
80JM/20/6/6/...	935	14 26 36	CT9	0.75	2.5	7.5	63	0.7
			F2265B	1.4	4	15	73	0.7
			F2269B	2.4	6.4	26	75	0.73
80JM/20/4/6/...	1440	12 22	F2245B	2.5	5.7	30	83	0.8
			F2249B	4.2	9	52	82	0.84
80JM/25/6/3/...	935	32	F2265B	1.4	4	15	73	0.7
80JM/25/4/3/...	1440	26 32	F2245B	2.5	5.7	30	83	0.8
			F2249B	4.2	9	52	82	0.84
80JM/25/6/6/...	935	30 36	F2265B	1.4	4	15	73	0.7
			F2269B	2.4	6.4	26	75	0.73
80JM/25/4/6/...	1440	16 26 36	F2245B	2.5	5.7	30	83	0.8
			F2249B	4.2	9	52	82	0.84
			DF132/MS	6.3	13.1	85	85	0.81
			DF132/M	10	20	140	87	0.83
80JM/25/6/9/...	935	24 36	F2265B	1.4	4	15	73	0.7
			F2269B	2.4	6.4	26	75	0.73
80JM/25/4/9/...	1440	10 20 28 36	F2245B	2.5	5.7	30	83	0.8
			F2249B	4.2	9	52	82	0.84
			DF132/MS	6.3	13.1	85	85	0.81
			DF132/M	10	20	140	87	0.83
90JM/25/6/3/...	935	30 32	F2265B	1.4	4	15	73	0.7
			F2269B	2.4	6.4	26	75	0.73
90JM/25/4/3/...	1440	18 26 32	F2245B	2.5	5.7	30	83	0.8
			F2249B	4.2	9	52	82	0.84
			DF132/MS	6.3	13.1	85	85	0.81
90JM/25/6/6/...	935	20 30 32	F2265B	1.4	4	15	73	0.7
			F2269B	2.4	6.4	26	75	0.73
			DF132/MS	3.5	8	44	83	0.76
90JM/25/4/6/...	1440	8 16 24 32	F2245B	2.5	5.7	30	83	0.8
			F2249B	4.2	9	52	82	0.84
			DF132/MS	6.3	13.1	85	85	0.81
			DF132/M	10	20	140	87	0.83
90JM/25/6/9/...	935	12 22 30 36	F2265B	1.4	4	15	73	0.7
			F2269B	2.4	6.4	26	75	0.73
			DF132/MS	3.5	8	44	83	0.76
			DF132/MA	4.6	10.5	58	83	0.76
90JM/25/4/9/...	1440	10 16 26 30 36	F2249B	4.2	9	52	82	0.84
			DF132/MS	6.3	13.1	85	85	0.81
			DF132/M	10	20	140	87	0.83
			DF160/LM	12.6	24	180	87	0.87
			DF160/L	17.3	32	240	89	0.88
100JM/25/6/3/...	935	22 32	F2265B	1.4	4	15	73	0.7
			F2269B	2.4	6.4	26	75	0.73

JM AEROFOIL - H.T. SERIES



Motor Frame Size Schedules: H.T. 250/2 & H.T. 300/0.5

400 V / 50 Hz / 3 ϕ

Code	Speed rev/min	Max. Pitch Angle (°)	Motor	Motor Rating (kW)	Full Load Current (A)	Starting Current d.o.l (A)	Efficiency %	Power Factor cos \emptyset
100JM/25/4/3/...	1440	10	F2245B	2.5	5.7	30	83	0.8
		18	F2249B	4.2	9	52	82	0.84
		26	DF132/MS	6.3	13.1	85	85	0.81
		32	DF132/M	10	20	140	87	0.83
100JM/25/6/6/...	950	12	F2265B	1.4	4	15	73	0.7
		22	F2269B	2.4	6.4	26	75	0.73
		28	DF132/MS	3.5	8	44	83	0.76
		32	DF132/MA	4.6	10.5	58	83	0.76
100JM/25/4/6/...	1450	10	F2249B	4.2	9	52	82	0.84
		16	DF132/MS	6.3	13.1	85	85	0.81
		24	DF132/M	10	20	140	87	0.83
		28	DF160/LM	12.6	24	180	87	0.87
100JM/25/6/9/...	960	14	F2269B	2.4	6.4	26	75	0.73
		20	DF132/MS	3.5	8	44	83	0.76
		26	DF132/MA	4.6	10.5	58	83	0.76
		36	DF132/MB	7	15.5	82.5	85	0.76
100JM/25/4/9/...	1470	8	DF132/MS	6.3	13.1	85	85	0.81
		16	DF132/M	10	20	140	87	0.83
		20	DF160/LM	12.6	24	180	87	0.87
		28	DF160/L	17.3	32	240	89	0.88
		32	DF160/LAK	22	40	300	89	0.88
		36	DF160/LBK	25	44	330	90	0.91
100JM/31/4/9/...	1470	8	DF132/MS	6.3	13.1	85	85	0.81
		16	DF132/M	10	20	140	87	0.83
		20	DF160/LM	12.6	24	180	87	0.87
		26	DF160/L	17.3	32	240	89	0.88
		32	DF160/LAK	22	40	300	89	0.88
		36	DF160/LBK	25	44	330	90	0.91

JM AEROFOIL - H.T. SERIES



Motor Frame Size Schedules: H.T. 300/1

400 V / 50 Hz / 3 ϕ

Code	Speed rev/min	Pitch Angle Range (°)	Motor	Motor Rating (kW)	Full Load Current (A)	Starting Current d.o.l. (A)	Efficiency %	Power Factor cos ϕ
31JM/16/6/5/...	900	40	D80/A	0.42	1.7	5	64	0.57
31JM/16/4/5/...	1420	40	D80/A	0.65	1.9	7	73	0.69
31JM/16/2/5/...	2840	40	D80/A	0.9	2.2	12	78	0.75
35JM/16/6/5/...	900	40	D80/A	0.42	1.7	5	64	0.57
35JM/16/4/5/...	1420	40	D80/A	0.65	1.9	7	73	0.69
35JM/16/2/5/...	2840	32 40	D80/A D80/B	0.9 1.3	2.2 3	12 19	78 79	0.75 0.78
40JM/16/6/5/...	900	40	D80/A	0.42	1.7	5	64	0.57
40JM/16/4/5/...	1420	40	D80/A	0.65	1.9	7	73	0.69
40JM/16/2/5/...	2840	20 26	D80/A D80/B	0.9 1.3	2.2 3	12 19	78 79	0.75 0.78
45JM/16/6/5/...	900	40	D80/A	0.42	1.7	5	64	0.57
45JM/20/4/3/...	1420	36	D80/A	0.65	1.9	7	73	0.69
45JM/20/2/3/...	2910	18 24 30 36	D80/A D80/B D90/LNS D90/LN	0.9 1.3 1.75 2.5	2.2 3 3.6 5.2	12 19 23 34	78 79 78 80	0.75 0.78 0.85 0.86
45JM/20/6/6/...	900	40	D80/A	0.42	1.7	5	64	0.57
45JM/20/4/6/...	1420	40	D80/A	0.65	1.9	7	73	0.69
45JM/20/2/6/...	2910	10 16 20 26 34 40	D80/A D80/B D90/LNS D90/LN D100/L DF112/M	0.9 1.3 1.75 2.5 3.5 4.6	2.2 3 3.6 5.2 6.9 8.8	12 19 23 34 52 66	78 79 78 80 83 86	0.75 0.78 0.85 0.86 0.88 0.87
50JM/16/6/5/...	915	40	D80/A	0.42	1.7	5	64	0.57
50JM/16/4/5/...	1420	38 40	D80/A D80/B	0.65 0.9	1.9 2.5	7 11	73 76	0.69 0.69
50JM/16/2/5/...	2840	10	D80/B	1.3	3	19	79	0.78
50JM/20/6/3/...	915	36	D80/A	0.42	1.7	5	64	0.57
50JM/20/4/3/...	1420	36	D80/A	0.65	1.9	7	73	0.69
50JM/20/2/3/...	2910	12 16 22 26 34 36	D80/A D80/B D90/LNS D90/LN D100/L DF112/M	0.9 1.3 1.75 2.5 3.5 4.6	2.2 3 3.6 5.2 6.9 8.8	12 19 23 34 52 66	78 79 78 80 83 86	0.75 0.78 0.85 0.86 0.88 0.87
50JM/20/6/6/...	915	40	D80/A	0.42	1.7	5	64	0.57

JM AEROFOIL - H.T. SERIES



Motor Frame Size Schedules: H.T. 300/1

400 V / 50 Hz / 3 ϕ

Code	Speed rev/min	Pitch Angle Range (°)	Motor	Motor Rating (kW)	Full Load Current (A)	Starting Current d.o.l. (A)	Efficiency %	Power Factor cos ϕ
50JM/20/4/6/...	1420	36	D80/A	0.65	1.9	7	73	0.69
		40	D80/B	0.9	2.5	11	76	0.69
		24	D100/L	3.5	6.9	52	83	0.88
		28	DF112/M	4.6	8.8	66	86	0.87
50JM/20/2/6/...	2910	10	D80/B	1.3	3	19	79	0.78
		12	D90/LNS	1.75	3.6	23	78	0.85
		18	D90/LN	2.5	5.2	34	80	0.86
56JM/16/8/5/...	680	40	D80/A	0.2	1.1	3	56	0.47
56JM/16/6/5/...	900	40	D80/A	0.42	1.7	5	64	0.57
56JM/16/4/5/...	1420	26	D80/A	0.65	1.9	7	73	0.69
		32	D80/B	0.9	2.5	11	76	0.69
56JM/20/6/3/...	900	36	D80/A	0.42	1.7	5	64	0.57
56JM/20/4/3/...	1420	34	D80/A	0.65	1.9	7	73	0.69
		36	D80/B	0.9	2.5	11	76	0.69
56JM/20/2/3/...	2910	10	D80/B	1.3	3	19	79	0.78
		14	D90/LNS	1.75	3.6	23	78	0.85
		18	D90/LN	2.5	5.2	34	80	0.86
		24	D100/L	3.5	6.9	52	83	0.88
		28	DF112/M	4.6	8.8	66	86	0.87
56JM/20/6/6/...	900	40	D80/A	0.42	1.7	5	64	0.57
56JM/20/4/6/...	1420	24	D80/A	0.65	1.9	7	73	0.69
		30	D80/B	0.9	2.5	11	76	0.69
		40	D90/LNS	1.35	3.2	16	77	0.73
		40	D90/LNS	1.35	3.2	16	77	0.73
56JM/20/2/6/...	2910	10	D90/LN	2.5	5.2	34	80	0.86
		14	D100/L	3.5	6.9	52	83	0.88
		18	DF112/M	4.6	8.8	66	86	0.87
63JM/20/8/3/...	680	36	D80/A	0.2	1.1	3	56	0.47
63JM/20/6/3/...	900	36	D80/A	0.42	1.7	5	64	0.57
63JM/20/4/3/...	1420	20	D80/A	0.65	1.9	7	73	0.69
		26	D80/B	0.9	2.5	11	76	0.69
		34	D90/LNS	1.35	3.2	16	77	0.73
		36	D90/LN	1.75	4.4	22	78	0.73
63JM/20/8/6/...	680	28	D80/A	0.2	1.1	3	56	0.47
		36	D80/B	0.28	1.4	4	58	0.5
63JM/20/6/6/...	900	30	D80/A	0.42	1.7	5	64	0.57
		36	D80/B	0.65	2.2	8	68	0.63
63JM/20/4/6/...	1420	12	D80/A	0.65	1.9	7	73	0.69
		18	D80/B	0.9	2.5	11	76	0.69
		24	D90/LNS	1.35	3.2	16	77	0.73
		28	D90/LN	1.75	4.4	22	78	0.73
		36	D100/LA	2.5	5.9	34	79	0.78
63JM/25/2/3/...	2910	18	DF112/M	4.6	8.8	66	86	0.87
		24	DF132/MSA	6.3	12	84	86	0.88
		28	DF132/MSB	8.6	16.3	114	86	0.88
		32	DF132/M	12	22	165	88	0.9

JM AEROFOIL - H.T. SERIES



Motor Frame Size Schedules: H.T. 300/1

400 V / 50 Hz / 3 ϕ

Code	Speed rev/min	Pitch Angle Range (°)	Motor	Motor Rating (kW)	Full Load Current (A)	Starting Current d.o.l. (A)	Efficiency %	Power Factor cos ϕ
63JM/25/4/6/...	1440	36	DF112/M	4.6	9.8	59	84	0.81
63JM/25/2/6/...	2910	12	DF112/M	4.6	8.8	66	86	0.87
		16	DF132/MSA	6.3	12	84	86	0.88
		20	DF132/MSB	8.6	16.3	114	86	0.88
		26	DF132/M	12	22	165	88	0.9
		28	DF160/LMA	12.6	24	180	87	0.87
		36	DF160/LMB	17.3	32	240	88	0.89
63JM/25/6/9/...	935	40	DF112/M	2.5	6.9	31	77	0.68
63JM/25/4/9/...	1440	40	DF112/M	4.6	9.8	59	84	0.81
63JM/25/2/9/...	2910	8	DF112/M	4.6	8.8	66	86	0.87
		12	DF132/MSA	6.3	12	84	86	0.88
		16	DF132/MSB	8.6	16.3	114	86	0.88
		22	DF132/M	12	22	165	88	0.9
		22	DF160/LMA	12.6	24	180	87	0.87
		28	DF160/LMB	17.3	32	240	88	0.89
		36	DF160/L	22	38	285	90	0.91
		40	DF160/LKE	30	53	398	90	0.91
		71JM/20/8/3/...	680	26	D80/A	0.2	1.1	3
34	D80/B			0.28	1.4	4	58	0.5
36	D90/LNS			0.42	2	6	60	0.51
71JM/20/6/3/...	900	28	D80/A	0.42	1.7	5	64	0.57
		36	D80/B	0.65	2.2	8	68	0.63
71JM/20/4/3/...	1440	16	D80/B	0.9	2.5	11	76	0.69
		24	D90/LNS	1.35	3.2	16	77	0.73
		28	D90/LN	1.75	4.4	22	78	0.73
		36	D100/LA	2.5	5.9	34	79	0.78
71JM/20/8/6/...	680	16	D80/A	0.2	1.1	3	56	0.47
		22	D80/B	0.28	1.4	4	58	0.5
		32	D90/LNS	0.42	2	6	60	0.51
		36	D90/LN	0.63	2.7	8	63	0.64
71JM/20/6/6/...	900	18	D80/A	0.42	1.7	5	64	0.57
		26	D80/B	0.65	2.2	8	68	0.63
		34	D90/LNS	0.85	2.9	10	65	0.67
		36	D90/LN	1.25	3.8	13	70	0.68
71JM/20/4/6/...	1440	14	D90/LNS	1.35	3.2	16	77	0.73
		18	D90/LN	1.75	4.4	22	78	0.73
		24	D100/LA	2.5	5.9	34	79	0.78
		32	D100/LB	3.5	8.1	49	82	0.76
		36	DF112/M	4.6	9.8	59	84	0.81
71JM/25/4/3/...	1440	32	DF112/M	4.6	9.8	59	84	0.81
71JM/25/8/6/...	695	36	DF112/M	1.7	5.7	23	70	0.7
71JM/25/6/6/...	935	36	DF112/M	2.5	6.9	31	77	0.68
71JM/25/4/6/...	1440	36	DF112/M	4.6	9.8	59	84	0.81
71JM/25/8/9/...	695	36	DF112/M	1.7	5.7	23	70	0.7

JM AEROFOIL - H.T. SERIES



Motor Frame Size Schedules: H.T. 300/1

400 V / 50 Hz / 3 ϕ

Code	Speed rev/min	Pitch Angle Range (°)	Motor	Motor Rating (kW)	Full Load Current (A)	Starting Current d.o.l. (A)	Efficiency %	Power Factor cos ϕ
71JM/25/6/9/...	935	36	DF112/M	2.5	6.9	31	77	0.68
71JM/25/4/9/...	1440	36	DF112/M	4.6	9.8	59	84	0.81
71JM/31/2/9/...	2910	8	DF132/MSB	8.6	16.3	114	86	0.88
		12	DF132/M	12	22	165	88	0.9
		12	DF160/LMA	12.6	24	180	87	0.87
		18	DF160/LMB	17.3	32	240	88	0.89
		22	DF160/L	22	38	285	90	0.91
		28	DF160/LKE	30	53	398	90	0.91
		32	DF180/LA	34	59	443	90	0.92
38	DF180/LB	40	68	510	92	0.92		
80JM/20/8/3/...	695	18	D80/A	0.2	1.1	3	56	0.47
		24	D80/B	0.28	1.4	4	58	0.5
		32	D90/LNS	0.42	2	6	60	0.51
		36	D90/LN	0.63	2.7	8	63	0.64
80JM/20/6/3/...	935	20	D80/A	0.42	1.7	5	64	0.57
		26	D80/B	0.65	2.2	8	68	0.63
		34	D90/LNS	0.85	2.9	10	65	0.67
		36	D90/LN	1.25	3.8	13	70	0.68
80JM/20/4/3/...	1440	16	D90/LNS	1.35	3.2	16	77	0.73
		18	D90/LN	1.75	4.4	22	78	0.73
		24	D100/LA	2.5	5.9	34	79	0.78
		32	D100/LB	3.5	8.1	49	82	0.76
		36	DF112/M	4.6	9.8	59	84	0.81
80JM/20/8/6/...	695	8	D80/A	0.2	1.1	3	56	0.47
		22	D90/LNS	0.42	2	6	60	0.51
		30	D90/LN	0.63	2.7	8	63	0.64
		36	D100/LA	0.85	2.7	10	68	0.65
80JM/20/6/6/...	935	16	D80/B	0.65	2.2	8	68	0.63
		22	D90/LNS	0.85	2.9	10	65	0.67
		28	D90/LN	1.25	3.8	13	70	0.68
		36	D100/L	1.7	5.4	22	74	0.62
80JM/20/4/6/...	1440	10	D90/LN	1.75	4.4	22	78	0.73
		16	D100/LA	2.5	5.9	34	79	0.78
		20	D100/LB	3.5	8.1	49	82	0.76
		26	DF112/M	4.6	9.8	59	84	0.81
80JM/25/8/3/...	695	32	DF112/M	1.7	5.7	23	70	0.7
80JM/25/6/3/...	935	32	DF112/M	2.5	6.9	31	77	0.68
80JM/25/4/3/...	1440	32	DF112/M	4.6	9.8	59	84	0.81
80JM/25/8/6/...	695	36	DF112/M	1.7	5.7	23	70	0.7
80JM/25/6/6/...	935	36	DF112/M	2.5	6.9	31	77	0.68
80JM/25/4/6/...	1440	30	DF112/M	4.6	9.8	59	84	0.81
		36	DF132/MS	6.3	13.1	85	85	0.81
80JM/25/8/9/...	695	36	DF112/M	1.7	5.7	23	70	0.7
80JM/25/6/9/...	935	36	DF112/M	2.5	6.9	31	77	0.68

JM AEROFOIL - H.T. SERIES



Motor Frame Size Schedules: H.T. 300/1

400 V / 50 Hz / 3 ϕ

Code	Speed rev/min	Pitch Angle Range (°)	Motor	Motor Rating (kW)	Full Load Current (A)	Starting Current d.o.l. (A)	Efficiency %	Power Factor cos θ
80JM/25/4/9/...	1440	24	DF112/M	4.6	9.8	59	84	0.81
		30	DF132/MS	6.3	13.1	85	85	0.81
		36	DF132/M	10	20	140	87	0.83
90JM/25/8/3/...	695	32	DF112/M	1.7	5.7	23	70	0.7
90JM/25/6/3/...	935	32	DF112/M	2.5	6.9	31	77	0.68
		1440	32	DF112/M	4.6	9.8	59	84
90JM/25/8/6/...	695	32	DF112/M	1.7	5.7	23	70	0.7
90JM/25/6/6/...	935	32	DF112/M	2.5	6.9	31	77	0.68
90JM/25/4/6/...	1440	22	DF112/M	4.6	9.8	59	84	0.81
		26	DF132/MS	6.3	13.1	85	85	0.81
		32	DF132/M	10	20	140	87	0.83
90JM/25/8/9/...	695	36	DF112/M	1.7	5.7	23	70	0.7
90JM/25/6/9/...	935	28	DF112/M	2.5	6.9	31	77	0.68
		36	DF132/MS	3.5	8	44	83	0.76
90JM/25/4/9/...	1440	14	DF112/M	4.6	9.8	59	84	0.81
		18	DF132/MS	6.3	13.1	85	85	0.81
		28	DF132/M	10	20	140	87	0.83
		34	DF160/LM	12.6	24	168	87	0.87
		36	DF160/L	17.3	32	240	89	0.88
100JM/25/8/3/...	695	32	DF112/M	1.7	5.7	23	70	0.7
100JM/25/6/3/...	935	32	DF112/M	2.5	6.9	31	77	0.68
100JM/25/4/3/...	1440	22	DF112/M	4.6	9.8	59	84	0.81
		28	DF132/MS	6.3	13.1	85	85	0.81
		32	DF132/M	10	20	140	87	0.83
100JM/25/8/6/...	695	32	DF112/M	1.7	5.7	23	70	0.7
100JM/25/6/6/...	950	26	DF112/M	2.5	6.9	31	77	0.68
		32	DF132/MS	3.5	8	44	83	0.76
100JM/25/4/6/...	1450	12	DF112/M	4.6	9.8	59	84	0.81
		18	DF132/MS	6.3	13.1	85	85	0.81
		26	DF132/M	10	20	140	87	0.83
		30	DF160/LM	12.6	24	168	87	0.87
		32	DF160/L	17.3	32	240	89	0.88
100JM/25/8/9/...	695	26	DF112/M	1.7	5.7	23	70	0.7
		36	DF132/MS	2.7	7.1	39	78	0.7
100JM/25/6/9/...	960	18	DF112/M	2.5	6.9	31	77	0.68
		26	DF132/MS	3.5	8	44	83	0.76
		32	DF132/MA	4.6	10.5	58	83	0.76
		36	DF132/MB	6.3	14.2	78	84	0.76
100JM/25/4/9/...	1470	12	DF132/MS	6.3	13.1	85	85	0.81
		20	DF132/M	10	20	140	87	0.83
		24	DF160/LM	12.6	24	168	87	0.87
		30	DF160/L	17.3	32	240	89	0.88
		36	DF160/LAK	22	40	300	89	0.88

JM AEROFOIL - H.T. SERIES



Motor Frame Size Schedules: H.T. 300/1

400 V / 50 Hz / 3 ϕ

Code	Speed rev/min	Pitch Angle Range (°)	Motor	Motor Rating (kW)	Full Load Current (A)	Starting Current d.o.l. (A)	Efficiency %	Power Factor cos ϕ
100JM/31/4/9/...	1470	12	DF132/MS	6.3	13.1	85	85	0.81
		20	DF132/M	10	20	140	87	0.83
		22	DF160/LM	12.6	24	168	87	0.87
		30	DF160/L	17.3	32	240	89	0.88
		36	DF160/LAK	22	40	300	89	0.88
100JM/40/4/9/...	1470	16	DF132/M	10	20	140	87	0.83
		20	DF160/LM	12.6	24	168	87	0.87
		26	DF160/L	17.3	32	240	89	0.88
		32	DF160/LAK	22	40	300	89	0.88
		34	DF160/LBK	25	44	330	90	0.91
		40	DF160/LKE	32	58	435	90	0.91
112JM/40/8/6/...	720	26	DF132/MS	2.7	7.1	39	78	0.7
		32	DF132/M	3.7	9.6	55	78	0.7
112JM/40/6/6/...	960	18	DF132/MS	3.5	8	44	83	0.76
		22	DF132/MA	4.6	10.5	58	83	0.76
		28	DF132/MB	6.3	14.2	78	84	0.76
		30	DF132/MB	7	15.5	85	85	0.76
		32	DF160/LM	8.6	18.5	111	87	0.77
112JM/40/4/6/...	1470	14	DF132/M	10	20	140	87	0.83
		16	DF160/LM	12.6	24	168	87	0.87
		22	DF160/L	17.3	32	240	89	0.88
		26	DF160/LAK	22	40	300	89	0.88
		28	DF160/LBK	25	44	330	90	0.91
		32	DF160/LKE	32	58	435	90	0.91
112JM/40/8/9/...	720	22	DF132/MS	2.7	7.1	39	78	0.7
		28	DF132/M	3.7	9.6	55	78	0.7
		36	DF160/LMA	5.5	12.1	73	84	0.75
112JM/40/6/9/...	960	12	DF132/MS	3.5	8	44	83	0.76
		18	DF132/MA	4.6	10.5	58	83	0.76
		24	DF132/MB	6.3	14.2	78	84	0.76
		26	DF132/MB	7	15.5	85	85	0.76
		28	DF160/LM	8.6	18.5	111	87	0.77
		36	DF160/L	12.6	27	162	87	0.77
112JM/40/4/9/...	1470	12	DF160/LM	12.6	24	168	87	0.87
		16	DF160/L	17.3	32	240	89	0.88
		20	DF160/LAK	22	40	300	89	0.88
		24	DF160/LBK	25	44	330	90	0.91
		28	DF160/LKE	32	58	435	90	0.91
		28	DF180/LB	35	62	434	91	0.9
		30	W200/LF	40	78	507	92	0.81
		36	W200/LFR	50	96	624	92	0.82
112JM/50/8/12/...	720	20	DF132/MS	2.7	7.1	39	78	0.7
		26	DF132/M	3.7	9.6	55	78	0.7
		34	DF160/LMA	5.5	12.1	73	84	0.75
		36	DF160/LMB	7	15.3	92	85	0.75
112JM/50/6/12/...	960	10	DF132/MS	3.5	8	44	83	0.76
		16	DF132/MA	4.6	10.5	58	83	0.76
		22	DF132/MB	6.3	14.2	78	84	0.76
		24	DF132/MB	7	15.5	85	85	0.76
		26	DF160/LM	8.6	18.5	111	87	0.77
		34	DF160/L	12.6	27	162	87	0.77
		36	DF160/LKE	18	36	216	88	0.81

JM AEROFOIL - H.T. SERIES



Motor Frame Size Schedules: H.T. 300/1

400 V / 50 Hz / 3 ϕ

Code	Speed rev/min	Pitch Angle Range (°)	Motor	Motor Rating (kW)	Full Load Current (A)	Starting Current d.o.l. (A)	Efficiency %	Power Factor cos ϕ		
112JM/50/4/12/...	1470	8	DF160/LM	12.6	24	168	87	0.87		
		16	DF160/L	17.3	32	240	89	0.88		
		20	DF160/LAK	22	40	300	89	0.88		
		22	DF160/LBK	25	44	330	90	0.91		
		26	DF160/LKE	32	58	435	90	0.91		
		26	DF180/LB	35	62	434	91	0.9		
		28	W200/LF	40	78	507	92	0.81		
		34	W200/LFR	50	96	624	92	0.82		
		36	W225/M	60	112	840	93	0.83		
		125JM/40/8/6/...	720	18	DF132/MS	2.7	7.1	39	78	0.7
24	DF132/M			3.7	9.6	55	78	0.7		
32	DF160/LMA			5.5	12.1	73	84	0.75		
125JM/40/6/6/...	960	12	DF132/MS	3.5	8	44	83	0.76		
		16	DF132/MA	4.6	10.5	58	83	0.76		
		20	DF132/MB	6.3	14.2	78	84	0.76		
		22	DF132/MB	7	15.5	85	85	0.76		
		24	DF160/LM	8.6	18.5	111	87	0.77		
		32	DF160/L	12.6	27	162	87	0.77		
125JM/40/4/6/...	1470	10	DF160/LM	12.6	24	168	87	0.87		
		14	DF160/L	17.3	32	240	89	0.88		
		18	DF160/LAK	22	40	300	89	0.88		
		20	DF160/LBK	25	44	330	90	0.91		
		24	DF160/LKE	32	58	435	90	0.91		
		24	DF180/LB	35	62	434	91	0.9		
		26	W200/LF	40	78	507	92	0.81		
		32	W200/LFR	50	96	624	92	0.82		
		125JM/40/8/9/...	720	14	DF132/MS	2.7	7.1	39	78	0.7
				18	DF132/M	3.7	9.6	55	78	0.7
26	DF160/LMA			5.5	12.1	73	84	0.75		
30	DF160/LMB			7	15.3	92	85	0.75		
36	DF160/L			9.5	21	137	85	0.75		
125JM/40/6/9/...	960			16	DF132/MB	6.3	14.2	78	84	0.76
		16	DF132/MB	7	15.5	85	85	0.76		
		18	DF160/LM	8.6	18.5	111	87	0.77		
		26	DF160/L	12.6	27	162	87	0.77		
		34	DF160/LKE	18	36	216	88	0.81		
		36	DF180/LA	21	40	260	89	0.85		
		125JM/40/4/9/...	1470	10	DF160/L	17.3	32	240	89	0.88
12	DF160/LAK			22	40	300	89	0.88		
16	DF160/LBK			25	44	330	90	0.91		
18	DF160/LKE			32	58	435	90	0.91		
20	DF180/LB			35	62	434	91	0.9		
20	W200/LF			40	78	507	92	0.81		
24	W200/LFR			50	96	624	92	0.82		
28	W225/M			60	112	840	93	0.83		
32	W225/MF			73	135	1010	93	0.84		
36	W250/M			99	179	1160	94	0.85		
125JM/50/8/6/...	720			18	DF132/MS	2.7	7.1	39	78	0.7
				24	DF132/M	3.7	9.6	55	78	0.7
				32	DF160/LMA	5.5	12.1	73	84	0.75
125JM/50/4/6/...	1470	10	DF160/LM	12.6	24	168	87	0.87		
		14	DF160/L	17.3	32	240	89	0.88		
		18	DF160/LAK	22	40	300	89	0.88		
		20	DF160/LBK	25	44	330	90	0.91		
		24	DF160/LKE	32	58	435	90	0.91		
		24	DF180/LB	35	62	434	91	0.9		
		26	W200/LF	40	78	507	92	0.81		
		30	W200/LFR	50	96	624	92	0.82		
		32	W225/M	60	112	840	93	0.83		

JM AEROFOIL - H.T. SERIES



Motor Frame Size Schedules: H.T. 300/1

400 V / 50 Hz / 3 ϕ

Code	Speed rev/min	Pitch Angle Range (°)	Motor	Motor Rating (kW)	Full Load Current (A)	Starting Current d.o.l. (A)	Efficiency %	Power Factor cos ϕ
125JM/50/4/9/...	1470	10	DF160/L	17.3	32	240	89	0.88
		14	DF160/LAK	22	40	300	89	0.88
		16	DF160/LBK	25	44	330	90	0.91
		20	DF160/LKE	32	58	435	90	0.91
		20	DF180/LB	35	62	434	91	0.9
		22	W200/LF	40	78	507	92	0.81
		26	W200/LFR	50	96	624	92	0.82
		30	W225/M	60	112	840	93	0.83
		34	W225/MF	73	135	1010	93	0.84
		36	W250/M	99	179	1160	94	0.85
125JM/50/8/12/...	720	10	DF132/MS	2.7	7.1	39	78	0.7
		16	DF132/M	3.7	9.6	55	78	0.7
		22	DF160/LMA	5.5	12.1	73	84	0.75
		26	DF160/LMB	7	15.3	92	85	0.75
		34	DF160/L	9.5	21	137	85	0.75
		36	DF160/LKE	13	28	182	86	0.76
125JM/50/6/12/...	960	12	DF132/MB	6.3	14.2	78	84	0.76
		14	DF132/MB	7	15.5	85	85	0.76
		16	DF160/LM	8.6	18.5	111	87	0.77
		22	DF160/L	12.6	27	162	87	0.77
		30	DF160/LKE	18	36	216	88	0.81
		34	DF180/LA	21	40	260	89	0.85
		36	DF180/LB	24	46	299	89	0.86
125JM/50/4/12/...	1470	10	DF160/LAK	22	40	300	89	0.88
		12	DF160/LBK	25	44	330	90	0.91
		16	DF160/LKE	32	58	435	90	0.91
		16	DF180/LB	35	62	434	91	0.9
		18	W200/LF	40	78	507	92	0.81
		22	W200/LFR	50	96	624	92	0.82
		26	W225/M	60	112	840	93	0.83
		30	W225/MF	73	135	1010	93	0.84
		36	W250/M	99	179	1160	94	0.85
		140JM/40/8/6/...	720	12	DF132/MS	2.7	7.1	39
16	DF132/M			3.7	9.6	55	78	0.7
22	DF160/LMA			5.5	12.1	73	84	0.75
26	DF160/LMB			7	15.3	92	85	0.75
34	DF160/L			9.5	21	137	85	0.75
36	DF160/LKE			13	28	182	86	0.76
140JM/40/6/6/...	960	12	DF132/MB	6.3	14.2	78	84	0.76
		14	DF132/MB	7	15.5	85	85	0.76
		16	DF160/LM	8.6	18.5	111	87	0.77
		22	DF160/L	12.6	27	162	87	0.77
		30	DF160/LKE	18	36	216	88	0.81
		34	DF180/LA	21	40	260	89	0.85
		36	DF180/LB	24	46	299	89	0.86
140JM/40/8/9/...	720	10	DF132/M	3.7	9.6	55	78	0.7
		18	DF160/LMA	5.5	12.1	73	84	0.75
		20	DF160/LMB	7	15.3	92	85	0.75
		26	DF160/L	9.5	21	137	85	0.75
		34	DF160/LKE	13	28	182	86	0.76
		36	DF180/LA	15.5	33	231	88	0.73
140JM/40/6/9/...	960	10	DF160/LM	8.6	18.5	111	87	0.77
		18	DF160/L	12.6	27	162	87	0.77
		24	DF160/LKE	18	36	216	88	0.81
		26	DF180/LA	21	40	260	89	0.85
		30	DF180/LB	24	46	299	89	0.86
		30	W200/LFG	27	55	330	90	0.79
		34	W200/LF	32	65	390	90	0.79
		36	W200/LFR	41	83	498	90	0.79

JM AEROFOIL - H.T. SERIES



Motor Frame Size Schedules: H.T. 300/1

400 V / 50 Hz / 3 ϕ

Code	Speed rev/min	Pitch Angle Range (°)	Motor	Motor Rating (kW)	Full Load Current (A)	Starting Current d.o.l. (A)	Efficiency %	Power Factor cos ϕ
140JM/50/8/9/...	720	12	DF132/M	3.7	9.6	55	78	0.7
		18	DF160/LMA	5.5	12.1	73	84	0.75
		22	DF160/LMB	7	15.3	92	85	0.75
		28	DF160/L	9.5	21	137	85	0.75
		34	DF160/LKE	13	28	182	86	0.76
		36	DF180/LA	15.5	33	231	88	0.73
140JM/50/8/12/...	720	8	DF132/M	3.7	9.6	55	78	0.7
		14	DF160/LMA	5.5	12.1	73	84	0.75
		18	DF160/LMB	7	15.3	92	85	0.75
		24	DF160/L	9.5	21	137	85	0.75
		30	DF160/LKE	13	28	182	86	0.76
		34	DF180/LA	15.5	33	231	88	0.73
140JM/50/6/12/...	960	8	DF160/LM	8.6	18.5	111	87	0.77
		14	DF160/L	12.6	27	162	87	0.77
		22	DF160/LKE	18	36	216	88	0.81
		24	DF180/LA	21	40	260	89	0.85
		26	DF180/LB	24	46	299	89	0.86
		28	W200/LFG	27	55	330	90	0.79
		32	W200/LF	32	65	390	90	0.79
160JM/40/8/6/...	720	14	DF160/LMA	5.5	12.1	73	84	0.75
		16	DF160/LMB	7	15.3	92	85	0.75
		20	DF160/L	9.5	21	137	85	0.75
		26	DF160/LKE	13	28	182	86	0.76
		30	DF180/LA	15.5	33	231	88	0.73
		32	DF180/LB	18.5	39	273	89	0.74
160JM/40/6/6/...	960	14	DF160/L	12.6	27	162	87	0.77
		20	DF160/LKE	18	36	216	88	0.81
		22	DF180/LA	21	40	260	89	0.85
		24	DF180/LB	24	46	299	89	0.86
		24	W200/LFG	27	55	330	90	0.79
		28	W200/LF	32	65	390	90	0.79
		32	W200/LFR	41	83	498	90	0.79
160JM/40/8/9/...	720	10	DF160/LMB	7	15.3	92	85	0.75
		16	DF160/L	9.5	21	137	85	0.75
		20	DF160/LKE	13	28	182	86	0.76
		24	DF180/LA	15.5	33	231	88	0.73
		28	DF180/LB	18.5	39	273	89	0.74
		30	W200/LF	22	49	270	89	0.73
		36	W200/LFR	27	60	330	89	0.73
160JM/40/6/9/...	960	14	DF160/LKE	18	36	216	88	0.81
		16	DF180/LA	21	40	260	89	0.85
		18	DF180/LB	24	46	299	89	0.86
		20	W200/LFG	27	55	330	90	0.79
		22	W200/LF	32	65	390	90	0.79
		26	W200/LFR	41	83	498	90	0.79
		26	W225/M	43	87	522	92	0.78
		32	W225/MF	53	108	648	92	0.77
		36	W250/M	62	120	720	93	0.8
160JM/50/6/9/...	960	10	DF160/L	12.6	27	162	87	0.77
		14	DF160/LKE	18	36	216	88	0.81
		16	DF180/LA	21	40	260	89	0.85
		18	DF180/LB	24	46	299	89	0.86
		20	W200/LFG	27	55	330	90	0.79
		22	W200/LF	32	65	390	90	0.79
		26	W200/LFR	41	83	498	90	0.79
		26	W225/M	43	87	522	92	0.78
		32	W225/MF	53	108	648	92	0.77
		34	W250/M	62	120	720	93	0.8
		36	W250/MF	76	145	870	93	0.81

JM AEROFOIL - H.T. SERIES



Motor Frame Size Schedules: H.T. 300/1

400 V / 50 Hz / 3 ϕ

Code	Speed rev/min	Pitch Angle Range (°)	Motor	Motor Rating (kW)	Full Load Current (A)	Starting Current d.o.l. (A)	Efficiency %	Power Factor cos ϕ
160JM/50/8/12/...	720	8	DF160/LMB	7	15.3	92	85	0.75
		12	DF160/L	9.5	21	137	85	0.75
		18	DF160/LKE	13	28	182	86	0.76
		20	DF180/LA	15.5	33	231	88	0.73
		24	DF180/LB	18.5	39	273	89	0.74
		26	W200/LF	22	49	270	89	0.73
		30	W200/LFR	27	60	330	89	0.73
		36	W225/M	32	69	380	91	0.74
160JM/50/6/12/...	960	10	DF160/LKE	18	36	216	88	0.81
		12	DF180/LA	21	40	260	89	0.85
		14	DF180/LB	24	46	299	89	0.86
		16	W200/LFG	27	55	330	90	0.79
		18	W200/LF	32	65	390	90	0.79
		22	W200/LFR	41	83	498	90	0.79
		24	W225/M	43	87	522	92	0.78
		28	W225/MF	53	108	648	92	0.77
		30	W250/M	62	120	720	93	0.8
		36	W250/MF	76	145	870	93	0.81

JM AEROFOIL - H.T. SERIES



Motor Frame Size Schedules:

H.T. 300/1: Two Speed (Full & Half Pole Change)

400 V / 50 Hz / 3 ϕ

Code	Speed rev/min	Max. Pitch Angle (°)	Motor	Motor Rating (kW)	Low Speed		Full Load Current (A)	Starting Current d.o.l (A)	Efficiency %	Power Factor cos ϕ
					rev/min	(kW)				
31JM/16/4-6/5/...	1420	40	D80/A	0.37	920	0.11	1.4/0.55	4.9/1.4	70/52	0.55/0.55
35JM/16/4-6/5/...	1420	40	D80/A	0.37	920	0.11	1.4/0.55	4.9/1.4	70/52	0.55/0.55
40JM/16/4-6/5/...	1420	40	D80/A	0.37	920	0.11	1.4/0.55	4.9/1.4	70/52	0.55/0.55
45JM/16/4-6/5/...	1420	32	D80/A	0.37	920	0.11	1.4/0.55	4.9/1.4	70/52	0.55/0.55
		40	D80/B	0.5	920	0.15	1.2/0.64	5.3/1.6	80/55	0.77/0.62
45JM/20/6-8/3/...	900	36	D90/LS	0.4	680	0.05	1.8/0.86	7.2/2.2	65/52	0.50/0.55
45JM/20/4-6/3/...	1420	36	D80/A	0.37	920	0.11	1.4/0.55	4.9/1.4	70/52	0.55/0.55
45JM/20/6-8/6/...	900	40	D90/LS	0.4	680	0.05	1.8/0.86	7.2/2.2	65/52	0.50/0.55
45JM/20/4-6/6/...	1420	32	D80/A	0.37	920	0.11	1.4/0.55	4.9/1.4	70/52	0.55/0.55
		40	D80/B	0.5	920	0.15	1.2/0.64	5.3/1.6	80/55	0.77/0.62
50JM/16/4-6/5/...	1420	22	D80/A	0.37	920	0.11	1.4/0.55	4.9/1.4	70/52	0.55/0.55
		28	D80/B	0.5	920	0.15	1.2/0.64	5.3/1.6	80/55	0.77/0.62
50JM/20/6-8/3/...	915	36	D90/LS	0.4	680	0.05	1.8/0.86	7.2/2.2	65/52	0.50/0.55
50JM/20/4-6/3/...	1420	32	D80/A	0.37	920	0.11	1.4/0.55	4.9/1.4	70/52	0.55/0.55
		36	D80/B	0.5	920	0.15	1.2/0.64	5.3/1.6	80/55	0.77/0.62
50JM/20/6-8/6/...	915	40	D90/LS	0.4	680	0.05	1.8/0.86	7.2/2.2	65/52	0.50/0.55
50JM/20/4-6/6/...	1420	22	D80/A	0.37	920	0.11	1.4/0.55	4.9/1.4	70/52	0.55/0.55
		26	D80/B	0.5	920	0.15	1.2/0.64	5.3/1.6	80/55	0.77/0.62
		34	D90/LS	0.67	910	0.2	1.5/0.73	7.6/2.2	80/60	0.79/0.66
		40	D90/LN	0.9	910	0.27	2.1/1.1	10.3/3.2	82/62	0.77/0.59
56JM/16/4-6/5/...	1420	14	D80/A	0.37	920	0.11	1.4/0.55	4.9/1.4	70/52	0.55/0.55
		18	D80/B	0.5	920	0.15	1.2/0.64	5.3/1.6	80/55	0.77/0.62
56JM/20/6-8/3/...	900	36	D90/LS	0.4	680	0.05	1.8/0.86	7.2/2.2	65/52	0.50/0.55
56JM/20/4-6/3/...	1420	22	D80/A	0.37	920	0.11	1.4/0.55	4.9/1.4	70/52	0.55/0.55
		28	D80/B	0.5	920	0.15	1.2/0.64	5.3/1.6	80/55	0.77/0.62
		32	D90/LS	0.67	910	0.2	1.5/0.73	7.6/2.2	80/60	0.79/0.66
		36	D90/LN	0.9	910	0.27	2.1/1.1	10.3/3.2	82/62	0.77/0.59
56JM/20/6-8/6/...	900	40	D90/LS	0.4	680	0.05	1.8/0.86	7.2/2.2	65/52	0.50/0.55
56JM/20/4-6/6/...	1420	12	D80/A	0.37	920	0.11	1.4/0.55	4.9/1.4	70/52	0.55/0.55
		18	D80/B	0.5	920	0.15	1.2/0.64	5.3/1.6	80/55	0.77/0.62
		22	D90/LS	0.67	910	0.2	1.5/0.73	7.6/2.2	80/60	0.79/0.66
		28	D90/LN	0.9	910	0.27	2.1/1.1	10.3/3.2	82/62	0.77/0.59
		40	D100/LA	1.7	940	0.49	4.2/2.3	25.2/8.1	78/56	0.75/0.61
63JM/20/6-8/3/...	900	34	D90/LS	0.4	680	0.05	1.8/0.86	7.2/2.2	65/52	0.50/0.55
		36	D90/L	0.6	680	0.08	2.5/1.2	10.2/3.0	68/54	0.50/0.55
63JM/20/4-6/3/...	1420	10	D80/A	0.37	920	0.11	1.4/0.55	4.9/1.4	70/52	0.55/0.55
		14	D80/B	0.5	920	0.15	1.2/0.64	5.3/1.6	80/55	0.77/0.62
		18	D90/LS	0.67	910	0.2	1.5/0.73	7.6/2.2	80/60	0.79/0.66
		24	D90/LN	0.9	910	0.27	2.1/1.1	10.3/3.2	82/62	0.77/0.59
		36	D100/LA	1.7	940	0.49	4.2/2.3	25.2/8.1	78/56	0.75/0.61

JM AEROFOIL - H.T. SERIES



Motor Frame Size Schedules: H.T. 300/1: Two Speed (Full & Half Pole Change)

400 V / 50 Hz / 3 ϕ

Code	Speed rev/min	Max. Pitch Angle (°)	Motor	Motor Rating (kW)	Low Speed		Full Load Current (A)	Starting Current d.o.l (A)	Efficiency %	Power Factor cos ϕ
					rev/min	(kW)				
63JM/20/6-8/6/...	900	24	D90/LS	0.4	680	0.05	1.8/0.86	7.2/2.2	65/52	0.50/0.55
		32	D90/L	0.6	680	0.08	2.5/1.2	10.2/3.0	68/54	0.50/0.55
		36	D100/LA	1	690	0.42	3.5/1.6	13.9/3.3	65/54	0.64/0.69
63JM/20/4-6/6/...	1420	10	D90/LS	0.67	910	0.2	1.5/0.73	7.6/2.2	80/60	0.79/0.66
		16	D90/LN	0.9	910	0.27	2.1/1.1	10.3/3.2	82/62	0.77/0.59
		26	D100/LA	1.7	940	0.49	4.2/2.3	25.2/8.1	78/56	0.75/0.61
		34	D100/LA	2.4	940	0.8	5.9/3.3	35.4/11.6	78/56	0.75/0.61
		36	D100/LB	3.3	940	1.1	8.1/4.6	48.9/16.2	78/56	0.75/0.61
63JM/25/6-8/3/...	935	32	DF112/M	2.2	690	1	6.9/3.6	27.6/7.2	72/58	0.64/0.69
63JM/25/4-6/3/...	1440	32	DF112/M	4.5	960	1.5	10.5/5.6	63/19.6	82/65	0.75/0.61
63JM/25/6-8/6/...	935	36	DF112/M	2.2	690	1	6.9/3.6	27.6/7.2	72/58	0.64/0.69
63JM/25/4-6/6/...	1440	36	DF112/M	4.5	960	1.5	10.5/5.6	63/19.6	82/65	0.75/0.61
63JM/25/6-8/9/...	935	40	DF112/M	2.2	690	1	6.9/3.6	27.6/7.2	72/58	0.64/0.69
63JM/25/4-6/9/...	1440	40	DF112/M	4.5	960	1.5	10.5/5.6	63/19.6	82/65	0.75/0.61
71JM/20/6-8/3/...	900	24	D90/LS	0.4	680	0.05	1.8/0.86	7.2/2.2	65/52	0.50/0.55
		32	D90/L	0.6	680	0.08	2.5/1.2	10.2/3.0	68/54	0.50/0.55
		36	D100/LA	1	690	0.42	3.5/1.6	13.9/3.3	65/54	0.64/0.69
71JM/20/4-6/3/...	1440	10	D90/LS	0.67	910	0.2	1.5/0.73	7.6/2.2	80/60	0.79/0.66
		14	D90/LN	0.9	910	0.27	2.1/1.1	10.3/3.2	82/62	0.77/0.59
		26	D100/LA	1.7	940	0.49	4.2/2.3	25.2/8.1	78/56	0.75/0.61
		32	D100/LA	2.4	940	0.8	5.9/3.3	35.4/11.6	78/56	0.75/0.61
		36	D100/LB	3.3	940	1.1	8.1/4.6	48.9/16.2	78/56	0.75/0.61
71JM/20/6-8/6/...	900	14	D90/LS	0.4	680	0.05	1.8/0.86	7.2/2.2	65/52	0.50/0.55
		20	D90/L	0.6	680	0.08	2.5/1.2	10.2/3.0	68/54	0.50/0.55
		30	D100/LA	1	690	0.42	3.5/1.6	13.9/3.3	65/54	0.64/0.69
		36	D100/LA	1.4	690	0.65	4.9/2.5	19.6/5.0	65/54	0.64/0.69
71JM/20/4-6/6/...	1440	16	D100/LA	1.7	940	0.49	4.2/2.3	25.2/8.1	78/56	0.75/0.61
		22	D100/LA	2.4	940	0.8	5.9/3.3	35.4/11.6	78/56	0.75/0.61
		28	D100/LB	3.3	940	1.1	8.1/4.6	48.9/16.2	78/56	0.75/0.61
		32	D100/LKE	3.8	940	1.3	9.4/5.3	56.4/18.6	78/56	0.75/0.61
		36	DF112/M	4.5	960	1.5	10.5/5.6	63/19.6	82/65	0.75/0.61
71JM/25/6-8/3/...	935	32	DF112/M	2.2	690	1	6.9/3.6	27.6/7.2	72/58	0.64/0.69
71JM/25/4-6/3/...	1440	32	DF112/M	4.5	960	1.5	10.5/5.6	63/19.6	82/65	0.75/0.61
71JM/25/6-8/6/...	935	36	DF112/M	2.2	690	1	6.9/3.6	27.6/7.2	72/58	0.64/0.69
71JM/25/4-6/6/...	1440	36	DF112/M	4.5	960	1.5	10.5/5.6	63/19.6	82/65	0.75/0.61
71JM/25/6-8/9/...	935	36	DF112/M	2.2	690	1	6.9/3.6	27.6/7.2	72/58	0.64/0.69
71JM/25/4-6/9/...	1440	32	DF112/M	4.5	960	1.5	10.5/5.6	63/19.6	82/65	0.75/0.61
		36	DF112/KE	5.5	960	1.85	12.8/6.8	76.8/23.8	82/65	0.75/0.61
80JM/20/6-8/3/...	935	14	D90/LS	0.4	680	0.05	1.8/0.86	7.2/2.2	65/52	0.50/0.55
		22	D90/L	0.6	680	0.08	2.5/1.2	10.2/3.0	68/54	0.50/0.55
		30	D100/LA	1	690	0.42	3.5/1.6	13.9/3.3	65/54	0.64/0.69
		36	D100/LA	1.4	690	0.65	4.9/2.5	19.6/5.0	65/54	0.64/0.69

JM AEROFOIL - H.T. SERIES



Motor Frame Size Schedules:

H.T. 300/1: Two Speed (Full & Half Pole Change)

400 V / 50 Hz / 3 ϕ

Code	Speed rev/min	Max. Pitch Angle (°)	Motor	Motor Rating (kW)	Low Speed		Full Load Current (A)	Starting Current d.o.l (A)	Efficiency %	Power Factor cos ϕ
					rev/min	(kW)				
80JM/20/4-6/3/...	1440	16	D100/LA	1.7	940	0.49	4.2/2.3	25.2/8.1	78/56	0.75/0.61
		22	D100/LA	2.4	940	0.8	5.9/3.3	35.4/11.6	78/56	0.75/0.61
		28	D100/LB	3.3	940	1.1	8.1/4.6	48.9/16.2	78/56	0.75/0.61
		32	D100/LKE	3.8	940	1.3	9.4/5.3	56.4/18.6	78/56	0.75/0.61
		36	DF112/M	4.5	960	1.5	10.5/5.6	63/19.6	82/65	0.75/0.61
80JM/20/6-8/6/...	935	12	D90/L	0.6	680	0.08	2.5/1.2	10.2/3.0	68/54	0.50/0.55
		18	D100/LA	1	690	0.42	3.5/1.6	13.9/3.3	65/54	0.64/0.69
		26	D100/LA	1.4	690	0.65	4.9/2.5	19.6/5.0	65/54	0.64/0.69
		30	D100/LB	1.8	690	0.8	6.2/3.0	24.8/6.0	66/55	0.64/0.69
		34	D100/LKE	2.1	690	0.95	7.2/3.5	28.8/7.2	66/55	0.64/0.69
		36	DF112/M	2.2	690	1	6.9/3.6	27.6/7.2	72/58	0.64/0.69
80JM/20/4-6/6/...	1440	8	D100/LA	1.7	940	0.49	4.2/2.3	25.2/8.1	78/56	0.75/0.61
		12	D100/LA	2.4	940	0.8	5.9/3.3	35.4/11.6	78/56	0.75/0.61
		18	D100/LB	3.3	940	1.1	8.1/4.6	48.9/16.2	78/56	0.75/0.61
		20	D100/LKE	3.8	940	1.3	9.4/5.3	56.4/18.6	78/56	0.75/0.61
		24	DF112/M	4.5	960	1.5	10.5/5.6	63/19.6	82/65	0.75/0.61
		28	DF112/KE	5.5	960	1.85	12.8/6.8	76.8/23.8	82/65	0.75/0.61
80JM/25/6-8/3/...	935	32	DF112/M	2.2	690	1	6.9/3.6	27.6/7.2	72/58	0.64/0.69
80JM/25/4-6/3/...	1440	32	DF112/M	4.5	960	1.5	10.5/5.6	63/19.6	82/65	0.75/0.61
80JM/25/6-8/6/...	935	36	DF112/M	2.2	690	1	6.9/3.6	27.6/7.2	72/58	0.64/0.69
80JM/25/4-6/6/...	1440	28	DF112/M	4.5	960	1.5	10.5/5.6	63/19.6	82/65	0.75/0.61
		32	DF112/KE	5.5	960	1.85	12.8/6.8	76.8/23.8	82/65	0.75/0.61
		34	DF132/MS	6.2	950	2	12.4/7.0	87/28	84/58	0.83/0.61
		36	DF132/M	7	950	2.3	14.3/7.5	100/30	85/70	0.83/0.64
80JM/25/6-8/9/...	935	32	DF112/M	2.2	690	1	6.9/3.6	27.6/7.2	72/58	0.64/0.69
		36	DF112/MK	2.5	690	1.15	7.8/4.1	31.2/8.2	72/58	0.64/0.69
80JM/25/4-6/9/...	1440	22	DF112/M	4.5	960	1.5	10.5/5.6	63/19.6	82/65	0.75/0.61
		26	DF112/KE	5.5	960	1.85	12.8/6.8	76.8/23.8	82/65	0.75/0.61
		28	DF132/MS	6.2	950	2	12.4/7.0	87/28	84/58	0.83/0.61
		30	DF132/M	7	950	2.3	14.3/7.5	100/30	85/70	0.83/0.64
		34	DF132/M	8.1	960	2.7	16.5/8.9	116/35.6	85/70	0.83/0.64
		36	D132/MKE	10	950	3.3	21.0/10.6	147/42.4	85/70	0.83/0.64
90JM/25/6-8/3/...	935	32	DF112/M	2.2	690	1	6.9/3.6	27.6/7.2	72/58	0.64/0.69
90JM/25/4-6/3/...	1440	28	DF112/M	4.5	960	1.5	10.5/5.6	63/19.6	82/65	0.75/0.61
		32	DF112/KE	5.5	960	1.85	12.8/6.8	76.8/23.8	82/65	0.75/0.61
90JM/25/6-8/6/...	935	28	DF112/M	2.2	690	1	6.9/3.6	27.6/7.2	72/58	0.64/0.69
		30	DF112/MK	2.5	690	1.15	7.8/4.1	31.2/8.2	72/58	0.64/0.69
		32	DF132/MS	3	710	1.3	7.9/4.1	47.5/12.3	79/70	0.70/0.65
90JM/25/4-6/6/...	1440	18	DF112/M	4.5	960	1.5	10.5/5.6	63/19.6	82/65	0.75/0.61
		22	DF112/KE	5.5	960	1.85	12.8/6.8	76.8/23.8	82/65	0.75/0.61
		24	DF132/MS	6.2	950	2	12.4/7.0	87/28	84/58	0.83/0.61
		26	DF132/M	7	950	2.3	14.3/7.5	100/30	85/70	0.83/0.64
		28	DF132/M	8.1	960	2.7	16.5/8.9	116/35.6	85/70	0.83/0.64
		32	D132/MKE	10	950	3.3	21.0/10.6	147/42.4	85/70	0.83/0.64
90JM/25/6-8/9/...	935	20	DF112/M	2.2	690	1	6.9/3.6	27.6/7.2	72/58	0.64/0.69
		22	DF112/MK	2.5	690	1.15	7.8/4.1	31.2/8.2	72/58	0.64/0.69
		26	DF132/MS	3	710	1.3	7.9/4.1	47.5/12.3	79/70	0.70/0.65
		30	DF132/MA	3.5	910	1.5	8.8/4.6	53/13.8	80/71	0.72/0.66
		36	DF132/MB	4.5	710	1.95	10.8/5.8	65/17.4	82/71	0.73/0.68

JM AEROFOIL - H.T. SERIES



Motor Frame Size Schedules: H.T. 300/1: Two Speed (Full & Half Pole Change)

400 V / 50 Hz / 3 ϕ

Code	Speed rev/min	Max. Pitch Angle (°)	Motor	Motor Rating (kW)	Low Speed		Full Load Current (A)	Starting Current d.o.l (A)	Efficiency %	Power Factor cos ϕ
					rev/min	(kW)				
90JM/25/4-6/9/...	1440	10	DF112/M	4.5	960	1.5	10.5/5.6	63/19.6	82/65	0.75/0.61
		14	DF112/KE	5.5	960	1.85	12.8/6.8	76.8/23.8	82/65	0.75/0.61
		16	DF132/MS	6.2	950	2	12.4/7.0	87/28	84/58	0.83/0.61
		18	DF132/M	7	950	2.3	14.3/7.5	100/30	85/70	0.83/0.64
		20	DF132/M	8.1	960	2.7	16.5/8.9	116/35.6	85/70	0.83/0.64
		26	D132/MKE	10	950	3.3	21.0/10.6	147/42.4	85/70	0.83/0.64
		30	DF160/LM	12	970	4	23.0/10.2	161/51	87/80	0.86/0.70
		36	DF160/L	16	970	5.3	30.0/13.0	210/78	89/83	0.86/0.70
100JM/25/6-8/3/...	935	30	DF112/M	2.2	690	1	6.9/3.6	27.6/7.2	72/58	0.64/0.69
		32	DF112/MK	2.5	690	1.15	7.8/4.1	31.2/8.2	72/58	0.64/0.69
100JM/25/4-6/3/...	1440	20	DF112/M	4.5	960	1.5	10.5/5.6	63/19.6	82/65	0.75/0.61
		24	DF112/KE	5.5	960	1.85	12.8/6.8	76.8/23.8	82/65	0.75/0.61
		26	DF132/MS	6.2	950	2	12.4/7.0	87/28	84/58	0.83/0.61
		28	DF132/M	7	950	2.3	14.3/7.5	100/30	85/70	0.83/0.64
		30	DF132/M	8.1	960	2.7	16.5/8.9	116/35.6	85/70	0.83/0.64
		32	D132/MKE	10	950	3.3	21.0/10.6	147/42.4	85/70	0.83/0.64
100JM/25/6-8/6/...	950	20	DF112/M	2.2	690	1	6.9/3.6	27.6/7.2	72/58	0.64/0.69
		22	DF112/MK	2.5	690	1.15	7.8/4.1	31.2/8.2	72/58	0.64/0.69
		24	DF132/MS	3	710	1.3	7.9/4.1	47.5/12.3	79/70	0.70/0.65
		28	DF132/MA	3.5	910	1.5	8.8/4.6	53/13.8	80/71	0.72/0.66
		32	DF132/MB	4.5	710	1.95	10.8/5.8	65/17.4	82/71	0.73/0.68
100JM/25/4-6/6/...	1450	10	DF112/M	4.5	960	1.5	10.5/5.6	63/19.6	82/65	0.75/0.61
		14	DF112/KE	5.5	960	1.85	12.8/6.8	76.8/23.8	82/65	0.75/0.61
		16	DF132/MS	6.2	950	2	12.4/7.0	87/28	84/58	0.83/0.61
		18	DF132/M	7	950	2.3	14.3/7.5	100/30	85/70	0.83/0.64
		20	DF132/M	8.1	960	2.7	16.5/8.9	116/35.6	85/70	0.83/0.64
		24	D132/MKE	10	950	3.3	21.0/10.6	147/42.4	85/70	0.83/0.64
		28	DF160/LM	12	970	4	23.0/10.2	161/51	87/80	0.86/0.70
		32	DF160/L	16	970	5.3	30.0/13.0	210/78	89/83	0.86/0.70
100JM/25/6-8/9/...	960	12	DF112/M	2.2	690	1	6.9/3.6	27.6/7.2	72/58	0.64/0.69
		16	DF112/MK	2.5	690	1.15	7.8/4.1	31.2/8.2	72/58	0.64/0.69
		18	DF132/MS	3	710	1.3	7.9/4.1	47.5/12.3	79/70	0.70/0.65
		20	DF132/MA	3.5	910	1.5	8.8/4.6	53/13.8	80/71	0.72/0.66
		26	DF132/MB	4.5	710	1.95	10.8/5.8	65/17.4	82/71	0.73/0.68
		28	D132/MK	5.1	710	2.2	12.3/6.5	74/19.8	82/71	0.73/0.68
		36	DF160/LM	7.5	710	3.2	16.2/8.2	105/32.8	85/78	0.78/0.72
		100JM/25/4-6/9/...	1470	8	DF112/KE	5.5	960	1.85	12.8/6.8	76.8/23.8
10	DF132/MS			6.2	950	2	12.4/7.0	87/28	84/58	0.83/0.61
12	DF132/M			7	950	2.3	14.3/7.5	100/30	85/70	0.83/0.64
14	DF132/M			8.1	960	2.7	16.5/8.9	116/35.6	85/70	0.83/0.64
18	D132/MKE			10	950	3.3	21.0/10.6	147/42.4	85/70	0.83/0.64
20	DF160/LM			12	970	4	23.0/10.2	161/51	87/80	0.86/0.70
26	DF160/L			16	970	5.3	30.0/13.0	210/78	89/83	0.86/0.70
28	DF160/LBK			18	970	6	34/15	238/90	89/83	0.86/0.70
32	DF160/LKE			22	980	7.3	41/18.2	287/109	89/83	0.86/0.70
100JM/31/4-6/9/...	1470			10	DF132/MS	6.2	950	2	12.4/7.0	87/28
		12	DF132/M	7	950	2.3	14.3/7.5	100/30	85/70	0.83/0.64
		14	DF132/M	8.1	960	2.7	16.5/8.9	116/35.6	85/70	0.83/0.64
		18	D132/MKE	10	950	3.3	21.0/10.6	147/42.4	85/70	0.83/0.64
		20	DF160/LM	12	970	4	23.0/10.2	161/51	87/80	0.86/0.70
		26	DF160/L	16	970	5.3	30.0/13.0	210/78	89/83	0.86/0.70
		28	DF160/LBK	18	970	6	34/15	238/90	89/83	0.86/0.70
		32	DF160/LKE	22	980	7.3	41/18.2	287/109	89/83	0.86/0.70
		30	DF180/LM	19.5	980	6.5	39/14.5	293/94.3	87/85	0.83/0.76
		34	DF180/L	23	980	7.7	45/16.8	338/109	88/86	0.84/0.77

JM AEROFOIL - H.T. SERIES



Motor Frame Size Schedules:

H.T. 300/1: Two Speed (Full & Half Pole Change)

400 V / 50 Hz / 3 ϕ

Code	Speed rev/min	Max. Pitch Angle (°)	Motor	Motor Rating (kW)	Low Speed		Full Load Current (A)	Starting Current d.o.l (A)	Efficiency %	Power Factor cos ϕ
					rev/min	(kW)				
100JM/40/6-8/6/...	960	20	DF132/MS	3	710	1.3	7.9/4.1	47.5/12.3	79/70	0.70/0.65
		22	DF132/MA	3.5	910	1.5	8.8/4.6	53/13.8	80/71	0.72/0.66
		26	DF132/MB	4.5	710	1.95	10.8/5.8	65/17.4	82/71	0.73/0.68
		28	D132/MK	5.1	710	2.2	12.3/6.5	74/19.8	82/71	0.73/0.68
		32	DF160/LM	7.5	710	3.2	16.2/8.2	105/32.8	85/78	0.78/0.72
100JM/40/4-6/6/...	1470	12	DF132/MS	6.2	950	2	12.4/7.0	87/28	84/58	0.83/0.61
		12	DF132/M	7	950	2.3	14.3/7.5	100/30	85/70	0.83/0.64
		14	DF132/M	8.1	960	2.7	16.5/8.9	116/35.6	85/70	0.83/0.64
		18	D132/MKE	10	950	3.3	21.0/10.6	147/42.4	85/70	0.83/0.64
		22	DF160/LM	12	970	4	23.0/10.2	161/51	87/80	0.86/0.70
		28	DF160/L	16	970	5.3	30.0/13.0	210/78	89/83	0.86/0.70
		30	DF160/LBK	18	970	6	34/15	238/90	89/83	0.86/0.70
		32	DF160/LKE	22	980	7.3	41/18.2	287/109	89/83	0.86/0.70
112JM/40/6-8/6/...	960	12	DF132/MS	3	710	1.3	7.9/4.1	47.5/12.3	79/70	0.70/0.65
		14	DF132/MA	3.5	910	1.5	8.8/4.6	53/13.8	80/71	0.72/0.66
		18	DF132/MB	4.5	710	1.95	10.8/5.8	65/17.4	82/71	0.73/0.68
		20	D132/MK	5.1	710	2.2	12.3/6.5	74/19.8	82/71	0.73/0.68
		26	DF160/LM	7.5	710	3.2	16.2/8.2	105/32.8	85/78	0.78/0.72
		32	DF160/L	10	710	4.3	21/10.5	137/42	87/79	0.80/0.75
112JM/40/4-6/6/...	1470	8	DF132/M	8.1	960	2.7	16.5/8.9	116/35.6	85/70	0.83/0.64
		12	D132/MKE	10	950	3.3	21.0/10.6	147/42.4	85/70	0.83/0.64
		14	DF160/LM	12	970	4	23.0/10.2	161/51	87/80	0.86/0.70
		18	DF160/L	16	970	5.3	30.0/13.0	210/78	89/83	0.86/0.70
		20	DF160/LBK	18	970	6	34/15	238/90	89/83	0.86/0.70
		24	DF160/LKE	22	980	7.3	41/18.2	287/109	89/83	0.86/0.70
		22	DF180/LM	19.5	980	6.5	39/14.5	293/94.3	87/85	0.83/0.76
		24	DF180/L	23	980	7.7	45/16.8	338/109	88/86	0.84/0.77
		26	W200/LFG	26	960	8	48/19	312/104	90.6/85.1	0.86/0.70
		30	W200/LF	31	960	10	57/24	370/132	90.8/85.3	0.86/0.70
		32	W200/LFR	38	960	12	70/29	455/160	91/85.5	0.86/0.70
		112JM/40/6-8/9/...	960	10	DF132/MA	3.5	910	1.5	8.8/4.6	53/13.8
14	DF132/MB			4.5	710	1.95	10.8/5.8	65/17.4	82/71	0.73/0.68
16	D132/MK			5.1	710	2.2	12.3/6.5	74/19.8	82/71	0.73/0.68
22	DF160/LM			7.5	710	3.2	16.2/8.2	105/32.8	85/78	0.78/0.72
26	DF160/L			10	710	4.3	21/10.5	137/42	87/79	0.80/0.75
34	DF180/LM			14	720	6	28/14.6	182/59	87/78	0.81/0.77
36	DF180/L			17	720	7.3	34/17.8	221/71	87/78	0.84/0.76
112JM/40/4-6/9/...	1470	8	DF160/LM	12	970	4	23.0/10.2	161/51	87/80	0.86/0.70
		14	DF160/L	16	970	5.3	30.0/13.0	210/78	89/83	0.86/0.70
		16	DF160/LBK	18	970	6	34/15	238/90	89/83	0.86/0.70
		18	DF160/LKE	22	980	7.3	41/18.2	287/109	89/83	0.86/0.70
		16	DF180/LM	19.5	980	6.5	39/14.5	293/94.3	87/85	0.83/0.76
		20	DF180/L	23	980	7.7	45/16.8	338/109	88/86	0.84/0.77
		22	W200/LFG	26	960	8	48/19	312/104	90.6/85.1	0.86/0.70
		26	W200/LF	31	960	10	57/24	370/132	90.8/85.3	0.86/0.70
		30	W200/LFR	38	960	12	70/29	455/160	91/85.5	0.86/0.70
		34	W225/M	47	970	15	86/35	602/210	92/87.5	0.86/0.70
		36	W225/MF	58	980	19	104/44	728/264	92.5/89	0.86/0.70
		112JM/50/6-8/12/...	960	8	DF132/MA	3.5	910	1.5	8.8/4.6	53/13.8
12	DF132/MB			4.5	710	1.95	10.8/5.8	65/17.4	82/71	0.73/0.68
14	D132/MK			5.1	710	2.2	12.3/6.5	74/19.8	82/71	0.73/0.68
20	DF160/LM			7.5	710	3.2	16.2/8.2	105/32.8	85/78	0.78/0.72
26	DF160/L			10	710	4.3	21/10.5	137/42	87/79	0.80/0.75
32	DF180/LM			14	720	6	28/14.6	182/59	87/78	0.81/0.77
36	DF180/L			17	720	7.3	34/17.8	221/71	87/78	0.84/0.76

JM AEROFOIL - H.T. SERIES



Motor Frame Size Schedules: H.T. 300/1: Two Speed (Full & Other P.A.M. Wound)

400 V / 50 Hz / 3 ϕ

Code	Speed rev/min	Max. Pitch Angle (°)	Motor	Motor Rating (kW)	Low Speed		Full Load Current (A)	Starting Current d.o.l (A)	Efficiency %	Power Factor cos θ
					rev/min	(kW)				
112JM/50/4-6/12/...	1470	12	DF160/L	16	970	5.3	30.0/13.0	210/78	89/83	0.86/0.70
		14	DF160/LBK	18	970	6	34/15	238/90	89/83	0.86/0.70
		18	DF160/LKE	22	980	7.3	41/18.2	287/109	89/83	0.86/0.70
		16	DF180/LM	19.5	980	6.5	39/14.5	293/94.3	87/85	0.83/0.76
		18	DF180/L	23	980	7.7	45/16.8	338/109	88/86	0.84/0.77
		20	W200/LFG	26	960	8	48/19	312/104	90.6/85.1	0.86/0.70
		24	W200/LF	31	960	10	57/24	370/132	90.8/85.3	0.86/0.70
		28	W200/LFR	38	960	12	70/29	455/160	91/85.5	0.86/0.70
		32	W225/M	47	970	15	86/35	602/210	92/87.5	0.86/0.70
		36	W225/MF	58	980	19	104/44	728/264	92.5/89	0.86/0.70
125JM/40/6-8/6/...	960	8	DF132/MA	3.5	910	1.5	8.8/4.6	53/13.8	80/71	0.72/0.66
		12	DF132/MB	4.5	710	1.95	10.8/5.8	65/17.4	82/71	0.73/0.68
		12	D132/MK	5.1	710	2.2	12.3/6.5	74/19.8	82/71	0.73/0.68
		18	DF160/LM	7.5	710	3.2	16.2/8.2	105/32.8	85/78	0.78/0.72
		24	DF160/L	10	710	4.3	21/10.5	137/42	87/79	0.80/0.75
		30	DF180/LM	14	720	6	28/14.6	182/59	87/78	0.81/0.77
		32	DF180/L	17	720	7.3	34/17.8	221/71	87/78	0.84/0.76
125JM/40/4-6/6/...	1470	8	DF160/LM	12	970	4	23.0/10.2	161/51	87/80	0.86/0.70
		12	DF160/L	16	970	5.3	30.0/13.0	210/78	89/83	0.86/0.70
		14	DF160/LBK	18	970	6	34/15	238/90	89/83	0.86/0.70
		16	DF160/LKE	22	980	7.3	41/18.2	287/109	89/83	0.86/0.70
		14	DF180/LM	19.5	980	6.5	39/14.5	293/94.3	87/85	0.83/0.76
		16	DF180/L	23	980	7.7	45/16.8	338/109	88/86	0.84/0.77
		18	W200/LFG	26	960	8	48/19	312/104	90.6/85.1	0.86/0.70
		22	W200/LF	31	960	10	57/24	370/132	90.8/85.3	0.86/0.70
		26	W200/LFR	38	960	12	70/29	455/160	91/85.5	0.86/0.70
		30	W225/M	47	970	15	86/35	602/210	92/87.5	0.86/0.70
32	W225/MF	58	980	19	104/44	728/264	92.5/89	0.86/0.70		
125JM/40/6-8/9/...	960	8	D132/MK	5.1	710	2.2	12.3/6.5	74/19.8	82/71	0.73/0.68
		14	DF160/LM	7.5	710	3.2	16.2/8.2	105/32.8	85/78	0.78/0.72
		18	DF160/L	10	710	4.3	21/10.5	137/42	87/79	0.80/0.75
		24	DF180/LM	14	720	6	28/14.6	182/59	87/78	0.81/0.77
		28	DF180/L	17	720	7.3	34/17.8	221/71	87/78	0.84/0.76
		30	W200/LFG	18.6	720	8	38/22	266/99	89/82	0.78/0.65
		34	W200/LF	22	730	9.5	45/25	315/113	90/83	0.78/0.65
		36	W200/LFR	27	730	12	55/31	385/140	90/84	0.79/0.65
125JM/40/4-6/9/...	1470	8	DF160/LBK	18	970	6	34/15	238/90	89/83	0.86/0.70
		10	DF160/LKE	22	980	7.3	41/18.2	287/109	89/83	0.86/0.70
		8	DF180/LM	19.5	980	6.5	39/14.5	293/94.3	87/85	0.83/0.76
		12	DF180/L	23	980	7.7	45/16.8	338/109	88/86	0.84/0.77
		14	W200/LFG	26	960	8	48/19	312/104	90.6/85.1	0.86/0.70
		16	W200/LF	31	960	10	57/24	370/132	90.8/85.3	0.86/0.70
		20	W200/LFR	38	960	12	70/29	455/160	91/85.5	0.86/0.70
		24	W225/M	47	970	15	86/35	602/210	92/87.5	0.86/0.70
		28	W225/MF	58	980	19	104/44	728/264	92.5/89	0.86/0.70
		34	W250/M	79	980	26	142/62	994/372	93.2/89.2	0.86/0.68
36	W250/MF	95	985	31	171/74	1197/444	93.5/89.4	0.86/0.68		
125JM/50/6-8/6/...	960	8	DF132/MA	3.5	910	1.5	8.8/4.6	53/13.8	80/71	0.72/0.66
		12	DF132/MB	4.5	710	1.95	10.8/5.8	65/17.4	82/71	0.73/0.68
		12	D132/MK	5.1	710	2.2	12.3/6.5	74/19.8	82/71	0.73/0.68
		18	DF160/LM	7.5	710	3.2	16.2/8.2	105/32.8	85/78	0.78/0.72
		24	DF160/L	10	710	4.3	21/10.5	137/42	87/79	0.80/0.75
		30	DF180/LM	14	720	6	28/14.6	182/59	87/78	0.81/0.77
		32	DF180/L	17	720	7.3	34/17.8	221/71	87/78	0.84/0.76

JM AEROFOIL - H.T. SERIES



Motor Frame Size Schedules:

H.T. 300/1: Two Speed (Full & Other P.A.M. Wound)

400 V / 50 Hz / 3 ϕ

Code	Speed rev/min	Max. Pitch Angle (°)	Motor	Motor Rating (kW)	Low Speed		Full Load Current (A)	Starting Current d.o.l (A)	Efficiency %	Power Factor cos ϕ
					rev/min	(kW)				
125JM/50/4-6/6/...	1470	8	DF160/LM	12	970	4	23.0/10.2	161/51	87/80	0.86/0.70
		12	DF160/L	16	970	5.3	30.0/13.0	210/78	89/83	0.86/0.70
		14	DF160/LBK	18	970	6	34/15	238/90	89/83	0.86/0.70
		16	DF160/LKE	22	980	7.3	41/18.2	287/109	89/83	0.86/0.70
		14	DF180/LM	19.5	980	6.5	39/14.5	293/94.3	87/85	0.83/0.76
		16	DF180/L	23	980	7.7	45/16.8	338/109	88/86	0.84/0.77
		18	W200/LFG	26	960	8	48/19	312/104	90.6/85.1	0.86/0.70
		22	W200/LF	31	960	10	57/24	370/132	90.8/85.3	0.86/0.70
		26	W200/LFR	38	960	12	70/29	455/160	91/85.5	0.86/0.70
		30	W225/M	47	970	15	86/35	602/210	92/87.5	0.86/0.70
		32	W225/MF	58	980	19	104/44	728/264	92.5/89	0.86/0.70
		125JM/50/6-8/9/...	960	8	DF132/MB	4.5	710	1.95	10.8/5.8	65/17.4
8	D132/MK			5.1	710	2.2	12.3/6.5	74/19.8	82/71	0.73/0.68
14	DF160/LM			7.5	710	3.2	16.2/8.2	105/32.8	85/78	0.78/0.72
20	DF160/L			10	710	4.3	21/10.5	137/42	87/79	0.80/0.75
24	DF180/LM			14	720	6	28/14.6	182/59	87/78	0.81/0.77
28	DF180/L			17	720	7.3	34/17.8	221/71	87/78	0.84/0.76
30	W200/LFG			18.6	720	8	38/22	266/99	89/82	0.78/0.65
34	W200/LF			22	730	9.5	45/25	315/113	90/83	0.78/0.65
36	W200/LFR			27	730	12	55/31	385/140	90/84	0.79/0.65
125JM/50/4-6/9/...	1470	8	DF160/LBK	18	970	6	34/15	238/90	89/83	0.86/0.70
		12	DF160/LKE	22	980	7.3	41/18.2	287/109	89/83	0.86/0.70
		10	DF180/LM	19.5	980	6.5	39/14.5	293/94.3	87/85	0.83/0.76
		12	DF180/L	23	980	7.7	45/16.8	338/109	88/86	0.84/0.77
		14	W200/LFG	26	960	8	48/19	312/104	90.6/85.1	0.86/0.70
		18	W200/LF	31	960	10	57/24	370/132	90.8/85.3	0.86/0.70
		20	W200/LFR	38	960	12	70/29	455/160	91/85.5	0.86/0.70
		24	W225/M	47	970	15	86/35	602/210	92/87.5	0.86/0.70
		28	W225/MF	58	980	19	104/44	728/264	92.5/89	0.86/0.70
		34	W250/M	79	980	26	142/62	994/372	93.2/89.2	0.86/0.68
		36	W250/MF	95	985	31	171/74	1197/444	93.5/89.4	0.86/0.68
		125JM/50/6-8/12/...	960	10	DF160/LM	7.5	710	3.2	16.2/8.2	105/32.8
16	DF160/L			10	710	4.3	21/10.5	137/42	87/79	0.80/0.75
22	DF180/LM			14	720	6	28/14.6	182/59	87/78	0.81/0.77
24	DF180/L			17	720	7.3	34/17.8	221/71	87/78	0.84/0.76
26	W200/LFG			18.6	720	8	38/22	266/99	89/82	0.78/0.65
30	W200/LF			22	730	9.5	45/25	315/113	90/83	0.78/0.65
36	W200/LFR			27	730	12	55/31	385/140	90/84	0.79/0.65
125JM/50/4-6/12/...	1470	8	DF180/L	23	980	7.7	45/16.8	338/109	88/86	0.84/0.77
		10	W200/LFG	26	960	8	48/19	312/104	90.6/85.1	0.86/0.70
		14	W200/LF	31	960	10	57/24	370/132	90.8/85.3	0.86/0.70
		18	W200/LFR	38	960	12	70/29	455/160	91/85.5	0.86/0.70
		20	W225/M	47	970	15	86/35	602/210	92/87.5	0.86/0.70
		24	W225/MF	58	980	19	104/44	728/264	92.5/89	0.86/0.70
		32	W250/M	79	980	26	142/62	994/372	93.2/89.2	0.86/0.68
		36	W250/MF	95	985	31	171/74	1197/444	93.5/89.4	0.86/0.68
140JM/40/6-8/6/...	960	12	DF160/LM	7.5	710	3.2	16.2/8.2	105/32.8	85/78	0.78/0.72
		16	DF160/L	10	710	4.3	21/10.5	137/42	87/79	0.80/0.75
		20	DF180/LM	14	720	6	28/14.6	182/59	87/78	0.81/0.77
		24	DF180/L	17	720	7.3	34/17.8	221/71	87/78	0.84/0.76
		26	W200/LFG	18.6	720	8	38/22	266/99	89/82	0.78/0.65
		30	W200/LF	22	730	9.5	45/25	315/113	90/83	0.78/0.65
		36	W200/LFR	27	730	12	55/31	385/140	90/84	0.79/0.65

JM AEROFOIL - H.T. SERIES



Motor Frame Size Schedules:

H.T. 300/1: Two Speed (Full & Other P.A.M. Wound)

400 V / 50 Hz / 3 ϕ

Code	Speed rev/min	Max. Pitch Angle (°)	Motor	Motor Rating (kW)	Low Speed		Full Load Current (A)	Starting Current d.o.l (A)	Efficiency %	Power Factor cos ϕ
					rev/min	(kW)				
140JM/40/6-8/9/...	960	8	DF160/LM	7.5	710	3.2	16.2/8.2	105/32.8	85/78	0.78/0.72
		10	DF160/L	10	710	4.3	21/10.5	137/42	87/79	0.80/0.75
		16	DF180/LM	14	720	6	28/14.6	182/59	87/78	0.81/0.77
		18	DF180/L	17	720	7.3	34/17.8	221/71	87/78	0.84/0.76
		20	W200/LFG	18.6	720	8	38/22	266/99	89/82	0.78/0.65
		24	W200/LF	22	730	9.5	45/25	315/113	90/83	0.78/0.65
		30	W200/LFR	27	730	12	55/31	385/140	90/84	0.79/0.65
		32	W225/M	30	730	13	63/34	441/153	91/84	0.76/0.65
140JM/50/6-8/9/...	960	8	DF160/LM	7.5	710	3.2	16.2/8.2	105/32.8	85/78	0.78/0.72
		12	DF160/L	10	710	4.3	21/10.5	137/42	87/79	0.80/0.75
		16	DF180/LM	14	720	6	28/14.6	182/59	87/78	0.81/0.77
		20	DF180/L	17	720	7.3	34/17.8	221/71	87/78	0.84/0.76
		22	W200/LFG	18.6	720	8	38/22	266/99	89/82	0.78/0.65
		24	W200/LF	22	730	9.5	45/25	315/113	90/83	0.78/0.65
		30	W200/LFR	27	730	12	55/31	385/140	90/84	0.79/0.65
		34	W225/M	30	730	13	63/34	441/153	91/84	0.76/0.65
140JM/50/4-6/9/...	1470	8	W200/LFG	26	960	8	48/19	312/104	90.6/85.1	0.86/0.70
		10	W200/LF	31	960	10	57/24	370/132	90.8/85.3	0.86/0.70
		14	W200/LFR	38	960	12	70/29	455/160	91/85.5	0.86/0.70
		16	W225/M	47	970	15	86/35	602/210	92/87.5	0.86/0.70
		20	W225/MF	58	980	19	104/44	728/264	92.5/89	0.86/0.70
		26	W250/M	79	980	26	142/62	994/372	93.2/89.2	0.86/0.68
140JM/50/6-8/12/...	960	8	DF160/L	10	710	4.3	21/10.5	137/42	87/79	0.80/0.75
		14	DF180/LM	14	720	6	28/14.6	182/59	87/78	0.81/0.77
		16	DF180/L	17	720	7.3	34/17.8	221/71	87/78	0.84/0.76
		18	W200/LFG	18.6	720	8	38/22	266/99	89/82	0.78/0.65
		22	W200/LF	22	730	9.5	45/25	315/113	90/83	0.78/0.65
		26	W200/LFR	27	730	12	55/31	385/140	90/84	0.79/0.65
		28	W225/M	30	730	13	63/34	441/153	91/84	0.76/0.65
		34	W225/MF	37	730	18	77/42	539/189	91/84	0.76/0.65
		36	W250/M	45	730	20	88/48	616/216	92/88	0.80/0.66
		140JM/50/4-6/12/...	1470	8	W200/LF	31	960	10	57/24	370/132
10	W200/LFR			38	960	12	70/29	455/160	91/85.5	0.86/0.70
12	W225/M			47	970	15	86/35	602/210	92/87.5	0.86/0.70
16	W225/MF			58	980	19	104/44	728/264	92.5/89	0.86/0.70
22	W250/M			79	980	26	142/62	994/372	93.2/89.2	0.86/0.68
26	W250/MF			95	985	31	171/74	1197/444	93.5/89.4	0.86/0.68
160JM/40/6-8/6/...	960	8	DF160/L	10	710	4.3	21/10.5	137/42	87/79	0.80/0.75
		12	DF180/LM	14	720	6	28/14.6	182/59	87/78	0.81/0.77
		14	DF180/L	17	720	7.3	34/17.8	221/71	87/78	0.84/0.76
		16	W200/LFG	18.6	720	8	38/22	266/99	89/82	0.78/0.65
		18	W200/LF	22	730	9.5	45/25	315/113	90/83	0.78/0.65
		24	W200/LFR	27	730	12	55/31	385/140	90/84	0.79/0.65
		26	W225/M	30	730	13	63/34	441/153	91/84	0.76/0.65
		30	W225/MF	37	730	18	77/42	539/189	91/84	0.76/0.65
		32	W250/M	45	730	20	88/48	616/216	92/88	0.80/0.66
		160JM/40/6-8/9/...	960	8	DF180/LM	14	720	6	28/14.6	182/59
10	DF180/L			17	720	7.3	34/17.8	221/71	87/78	0.84/0.76
10	W200/LFG			18.6	720	8	38/22	266/99	89/82	0.78/0.65
14	W200/LF			22	730	9.5	45/25	315/113	90/83	0.78/0.65
18	W200/LFR			27	730	12	55/31	385/140	90/84	0.79/0.65
20	W225/M			30	730	13	63/34	441/153	91/84	0.76/0.65
24	W225/MF			37	730	18	77/42	539/189	91/84	0.76/0.65
26	W250/M			45	730	20	88/48	616/216	92/88	0.80/0.66
30	W250/MF			55	740	24	107/59	749/266	93/88	0.80/0.66

JM AEROFOIL - H.T. SERIES



Motor Frame Size Schedules:

H.T. 300/1: Two Speed (Full & Other P.A.M. Wound)

400 V / 50 Hz / 3 ϕ

Code	Speed rev/min	Max. Pitch Angle (°)	Motor	Motor Rating (kW)	Low Speed		Full Load Current (A)	Starting Current d.o.l (A)	Efficiency %	Power Factor cos ϕ
					rev/min	(kW)				
160JM/50/6-8/9/...	960	8	DF180/LM	14	720	6	28/14.6	182/59	87/78	0.81/0.77
		10	DF180/L	17	720	7.3	34/17.8	221/71	87/78	0.84/0.76
		12	W200/LFG	18.6	720	8	38/22	266/99	89/82	0.78/0.65
		14	W200/LF	22	730	9.5	45/25	315/113	90/83	0.78/0.65
		18	W200/LFR	27	730	12	55/31	385/140	90/84	0.79/0.65
		20	W225/M	30	730	13	63/34	441/153	91/84	0.76/0.65
		24	W225/MF	37	730	18	77/42	539/189	91/84	0.76/0.65
		26	W250/M	45	730	20	88/48	616/216	92/88	0.80/0.66
		30	W250/MF	55	740	24	107/59	749/266	93/88	0.80/0.66
		160JM/50/6-8/12/...	960	8	W200/LFG	18.6	720	8	38/22	266/99
10	W200/LF			22	730	9.5	45/25	315/113	90/83	0.78/0.65
14	W200/LFR			27	730	12	55/31	385/140	90/84	0.79/0.65
16	W225/M			30	730	13	63/34	441/153	91/84	0.76/0.65
20	W225/MF			37	730	18	77/42	539/189	91/84	0.76/0.65
24	W250/M			45	730	20	88/48	616/216	92/88	0.80/0.66
26	W250/MF			55	740	24	107/59	749/266	93/88	0.80/0.66

JM AEROFOIL - H.T. SERIES



Motor Frame Size Schedules: H.T. 400/2

400 V / 50 Hz / 3 ϕ

Code	Speed rev/min	Max. Pitch Angle (°)	Motor	Motor Rating (kW)	Full Load Current (A)	Starting Current d.o.l (A)	Efficiency %	Power Factor cos ϕ
31JM/16/2/5/...	2840	40	D80/A	0.75	1.8	9.9	78	0.77
45JM/20/2/6/...	2910	8	D80/A	0.75	1.8	9.9	78	0.77
		12	D80/B	1.1	2.6	16.3	79	0.8
		16	D90/LNS	1.5	3.3	22.3	76	0.86
		22	D90/L	2.2	4.6	34.5	81	0.86
		28	D100/L	3	5.8	43.5	84	0.9
		36	DF112/M	4	7.5	56.3	86	0.9
50JM/16/4/5/...	1420	30	D80/A	0.55	1.6	6.4	73	0.7
		38	D80/B	0.75	1.9	8.6	77	0.7
50JM/20/4/6/...	1420	28	D80/A	0.55	1.6	6.4	73	0.7
		36	D80/B	0.75	1.9	8.6	77	0.7
56JM/16/4/5/...	1420	20	D80/A	0.55	1.6	6.4	73	0.7
		26	D80/B	0.75	1.9	8.6	77	0.7
56JM/20/4/3/...	1420	28	D80/A	0.55	1.6	6.4	73	0.7
		34	D80/B	0.75	1.9	8.6	77	0.7
		36	D90/LNS	1.1	3.1	14	79	0.65
56JM/20/4/6/...	1420	18	D80/A	0.55	1.6	6.4	73	0.7
		24	D80/B	0.75	1.9	8.6	77	0.7
		32	D90/LNS	1.1	3.1	14	79	0.65
		40	D90/LN	1.5	3.7	19.4	82	0.71
63JM/20/6/3/...	900	32	D80/A	0.37	1.4	4.2	65	0.58
		36	D80/B	0.55	1.7	6.4	70	0.64
63JM/20/4/3/...	1420	14	D80/A	0.55	1.6	6.4	73	0.7
		20	D80/B	0.75	1.9	8.6	77	0.7
		26	D90/LNS	1.1	3.1	14	79	0.65
		34	D90/LN	1.5	3.7	19.4	82	0.71
		36	D100/LA	2.2	5.2	30.2	79	0.78
63JM/20/6/6/...	900	22	D80/A	0.37	1.4	4.2	65	0.58
		30	D80/B	0.55	1.7	6.4	70	0.64
		36	D90/SN	0.75	2.4	9	71	0.62
63JM/20/4/6/...	1420	8	D80/A	0.55	1.6	6.4	73	0.7
		12	D80/B	0.75	1.9	8.6	77	0.7
		18	D90/LNS	1.1	3.1	14	79	0.65
		24	D90/LN	1.5	3.7	19.4	82	0.71
		32	D100/LA	2.2	5.2	30.2	79	0.78
		36	D100/LB	3	7.1	44.7	82	0.75
63JM/25/6/3/...	935	32	DF112/M	2.2	6.1	24.5	77	0.68
63JM/25/4/3/...	1440	32	DF112/M	4	8.7	50	83	0.8
63JM/25/4/3/...	1440	32	DF112/M	4	8.7	50	83	0.8
63JM/25/6/6/...	935	36	DF112/M	2.2	6.1	24.5	77	0.68
63JM/25/4/6/...	1440	36	DF112/M	4	8.7	50	83	0.8
63JM/25/6/9/...	935	40	DF112/M	2.2	6.1	24.5	77	0.68
63JM/25/4/9/...	1440	40	DF112/M	4	8.7	50	83	0.8
71JM/20/6/3/...	900	22	D80/A	0.37	1.4	4.2	65	0.58
		28	D80/B	0.55	1.7	6.4	70	0.64
		36	D90/SN	0.75	2.4	9	71	0.62

JM AEROFOIL - H.T. SERIES



Motor Frame Size Schedules: H.T. 400/2

400 V / 50 Hz / 3 ϕ

Code	Speed rev/min	Max. Pitch Angle (°)	Motor	Motor Rating (kW)	Full Load Current (A)	Starting Current d.o.l (A)	Efficiency %	Power Factor cos \emptyset
71JM/20/4/3/...	1440	10	D80/B	0.75	1.9	8.6	77	0.7
		16	D90/LNS	1.1	3.1	14	79	0.65
		22	D90/LN	1.5	3.7	19.4	82	0.71
		30	D100/LA	2.2	5.2	30.2	79	0.78
		36	D100/LB	3	7.1	44.7	82	0.75
71JM/20/6/6/...	900	12	D80/A	0.37	1.4	4.2	65	0.58
		18	D80/B	0.55	1.7	6.4	70	0.64
		24	D90/SN	0.75	2.4	9	71	0.62
		34	D90/LN	1.1	3.2	12	75	0.66
		36	D100/L	1.5	4.5	20.3	75	0.65
71JM/20/4/6/...	1440	8	D90/LNS	1.1	3.1	14	79	0.65
		12	D90/LN	1.5	3.7	19.4	82	0.71
		20	D100/LA	2.2	5.2	30.2	79	0.78
		26	D100/LB	3	7.1	44.7	82	0.75
		32	DF112/M	4	8.7	50	83	0.8
71JM/25/6/3/...	935	32	DF112/M	2.2	6.1	24.5	77	0.68
71JM/25/4/3/...	1440	32	DF112/M	4	8.7	50	83	0.8
71JM/25/6/6/...	935	36	DF112/M	2.2	6.1	24.5	77	0.68
71JM/25/4/6/...	1440	36	DF112/M	4	8.7	50	83	0.8
71JM/25/6/9/...	935	36	DF112/M	2.2	6.1	24.5	77	0.68
71JM/25/4/9/...	1440	30	DF112/M	4	8.7	50	83	0.8
		36	DF132/MS	5.5	11.1	75.5	86	0.83
80JM/20/6/3/...	935	12	D80/A	0.37	1.4	4.2	65	0.58
		18	D80/B	0.55	1.7	6.4	70	0.64
		24	D90/SN	0.75	2.4	9	71	0.62
		32	D90/LN	1.1	3.2	12	75	0.66
		36	D100/L	1.5	4.5	20.3	75	0.65
80JM/20/6/6/...	935	10	D80/B	0.55	1.7	6.4	70	0.64
		14	D90/SN	0.75	2.4	9	71	0.62
		22	D90/LN	1.1	3.2	12	75	0.66
		28	D100/L	1.5	4.5	20.3	75	0.65
		36	DF112/M	2.2	6.1	24.5	77	0.68
80JM/25/6/3/...	935	32	DF112/M	2.2	6.1	24.5	77	0.68
80JM/25/4/3/...	1440	32	DF112/M	4	8.7	50	83	0.8
80JM/25/6/6/...	935	36	DF112/M	2.2	6.1	24.5	77	0.68
80JM/25/4/6/...	1440	26	DF112/M	4	8.7	50	83	0.8
		32	DF132/MS	5.5	11.1	75.5	86	0.83
		36	DF132/M	7.5	15	113	87	0.83
80JM/25/6/9/...	935	32	DF112/M	2.2	6.1	24.5	77	0.68
		36	DF132/MS	3	6.8	41	82	0.77
80JM/25/4/9/...	1440	20	DF112/M	4	8.7	50	83	0.8
		26	DF132/MS	5.5	11.1	75.5	86	0.83
		32	DF132/M	7.5	15	113	87	0.83
		36	DF160/LM	11	20.8	135	88	0.86
90JM/25/6/3/...	935	32	DF112/M	2.2	6.1	24.5	77	0.68

JM AEROFOIL - H.T. SERIES



Motor Frame Size Schedules: H.T. 400/2

400 V / 50 Hz / 3 ϕ

Code	Speed rev/min	Max. Pitch Angle (°)	Motor	Motor Rating (kW)	Full Load Current (A)	Starting Current d.o.l (A)	Efficiency %	Power Factor cos ϕ
90JM/25/4/3/...	1440	26	DF112/M	4	8.7	50	83	0.8
		32	DF132/MS	5.5	11.1	75.5	86	0.83
90JM/25/6/6/...	935	28	DF112/M	2.2	6.1	24.5	77	0.68
		32	DF132/MS	3	6.8	41	82	0.77
90JM/25/4/6/...	1440	16	DF112/M	4	8.7	50	83	0.8
		22	DF132/MS	5.5	11.1	75.5	86	0.83
		28	DF132/M	7.5	15	113	87	0.83
		32	DF160/LM	11	20.8	135	88	0.86
90JM/25/6/9/...	935	20	DF112/M	2.2	6.1	24.5	77	0.68
		26	DF132/MS	3	6.8	41	82	0.77
		34	DF132/MA	4	9.3	51.2	83	0.74
		36	DF132/MB	5.5	12.8	70.4	85	0.73
90JM/25/4/9/...	1440	8	DF112/M	4	8.7	50	83	0.8
		14	DF132/MS	5.5	11.1	75.5	86	0.83
		20	DF132/M	7.5	15	113	87	0.83
		28	DF160/LM	11	20.8	135	88	0.86
		34	DF160/L	15	28	202	90	0.87
		36	DF160/LAK	18.5	34	255	89	0.88
100JM/25/6/3/...	935	30	DF112/M	2.2	6.1	24.5	77	0.68
		32	DF132/MS	3	6.8	41	82	0.77
100JM/25/4/3/...	1440	18	DF112/M	4	8.7	50	83	0.8
		24	DF132/MS	5.5	11.1	75.5	86	0.83
		28	DF132/M	7.5	15	113	87	0.83
		32	DF160/LM	11	20.8	135	88	0.86
100JM/25/6/6/...	950	20	DF112/M	2.2	6.1	24.5	77	0.68
		26	DF132/MS	3	6.8	41	82	0.77
		30	DF132/MA	4	9.3	51.2	83	0.74
		32	DF132/MB	5.5	12.8	70.4	85	0.73
100JM/25/4/6/...	1450	8	DF112/M	4	8.7	50	83	0.8
		14	DF132/MS	5.5	11.1	75.5	86	0.83
		18	DF132/M	7.5	15	113	87	0.83
		26	DF160/LM	11	20.8	135	88	0.86
		32	DF160/L	15	28	202	90	0.87
100JM/25/6/9/...	960	12	DF112/M	2.2	6.1	24.5	77	0.68
		18	DF132/MS	3	6.8	41	82	0.77
		24	DF132/MA	4	9.3	51.2	83	0.74
		30	DF132/MB	5.5	12.8	70.4	85	0.73
		36	DF160/LM	7.5	16.6	116	87	0.75
100JM/25/4/9/...	1470	8	DF132/MS	5.5	11.1	75.5	86	0.83
		12	DF132/M	7.5	15	113	87	0.83
		18	DF160/LM	11	20.8	135	88	0.86
		24	DF160/L	15	28	202	90	0.87
		28	DF160/LAK	18.5	34	255	89	0.88
		32	DF160/LBK	21	38	285	89	0.88
100JM/31/4/9/...	1470	8	DF132/MS	5.5	11.1	75.5	86	0.83
		12	DF132/M	7.5	15	113	87	0.83
		18	DF160/LM	11	20.8	135	88	0.86
		24	DF160/L	15	28	202	90	0.87
		28	DF160/LAK	18.5	34	255	89	0.88
		32	DF160/LBK	21	38	285	89	0.88

JM AEROFOIL - H.T. SERIES



Motor Frame Size Schedules:

H.T. 400/2: Two Speed (Full & Half Pole Change)

400 V / 50 Hz / 3 ϕ

Code	Speed rev/min	Max. Pitch Angle (°)	Motor	Motor Rating (kW)	Low Speed		Full Load Current (A)	Starting Current d.o.l (A)	Efficiency %	Power Factor cos ϕ
					rev/min	(kW)				
31JM/16/2-4/5/...	2840	32	D80/A	0.55	1440	0.07	Information available on request			
		40	D80/B	0.75	1440	0.09				
45JM/20/2-4/3/...	2910	10	D80/A	0.55	1440	0.07				
		14	D80/B	0.75	1440	0.09				
		20	D90/LS	1.1	1420	0.14				
		36	D100/LA	3	1440	0.6				
45JM/20/2-4/6/...	2910	8	D80/B	0.75	1440	0.09				
		12	D90/LS	1.1	1420	0.14				
		14	D90/L	1.3	1420	0.16				
		28	D100/LA	3	1440	0.6				
		36	DF112/M	4	1440	0.85				
50JM/20/4-8/3/...	1420	32	D80/A	0.4	700	0.05				
		36	D80/B	0.52	700	0.07				
50JM/20/4-8/6/...	1420	22	D80/A	0.4	700	0.05				
		26	D80/B	0.52	700	0.07				
		32	D90/LS	0.67	700	0.08				
		40	D90/L	1	700	0.12				
56JM/20/4-8/3/...	1420	22	D80/A	0.4	700	0.05				
		26	D80/B	0.52	700	0.07				
		32	D90/LS	0.67	700	0.08				
		36	D90/L	1	700	0.12				
56JM/20/4-8/6/...	1420	12	D80/A	0.4	700	0.05				
		16	D80/B	0.52	700	0.07				
		22	D90/LS	0.67	700	0.08				
		30	D90/L	1	700	0.12				
		40	D100/LA	1.85	700	0.48				
63JM/20/4-8/3/...	1420	12	D80/B	0.52	700	0.07				
		18	D90/LS	0.67	700	0.08				
		24	D90/L	1	700	0.12				
		36	D100/LA	1.85	700	0.48				
63JM/20/4-8/6/...	1420	10	D90/LS	0.67	700	0.08				
		16	D90/L	1	700	0.12				
		28	D100/LA	1.85	700	0.48				
		34	D100/LA	2.4	700	0.55				
		36	DF112/M	3.6	700	0.75				
63JM/25/4-8/3/...	1440	32	DF112/M	3.6	700	0.75				
63JM/25/4-8/6/...	1440	36	DF112/M	3.6	700	0.75				
63JM/25/4-8/9/...	1440	40	DF112/M	3.6	700	0.75				
71JM/20/4-8/3/...	1440	14	D90/L	1	700	0.12				
		26	D100/LA	1.85	700	0.48				
		32	D100/LA	2.4	700	0.55				
		36	DF112/M	3.6	700	0.75				
71JM/20/4-8/6/...	1440	16	D100/LA	1.85	700	0.48				
		20	D100/LA	2.4	700	0.55				
		30	DF112/M	3.6	700	0.75				
71JM/25/4-8/3/...	1440	32	DF112/M	3.6	700	0.75				
71JM/25/4-8/6/...	1440	34	DF112/M	3.6	700	0.75				
		36	DF132/MS	4.8	700	1.1				

JM AEROFOIL - H.T. SERIES



Motor Frame Size Schedules: H.T. 400/2: Two Speed (Full & Half Pole Change)

400 V / 50 Hz / 3 ϕ

Code	Speed rev/min	Max. Pitch Angle (°)	Motor	Motor Rating (kW)	Low Speed		Full Load Current (A)	Starting Current d.o.l (A)	Efficiency %	Power Factor cos ϕ
					rev/min	(kW)				
71JM/25/4-8/9/...	1440	28	DF112/M	3.6	700	0.75	Information available on request			
		34	DF132/MS	4.8	700	1.1				
		36	DF132/M	6.7	700	1.5				
80JM/25/4-8/3/...	1440	32	DF112/M	3.6	700	0.75				
80JM/25/4-8/6/...	1440	24	DF112/M	3.6	700	0.75				
		28	DF132/MS	4.8	700	1.1				
		36	DF132/M	6.7	700	1.5				
80JM/25/4-8/9/...	1440	18	DF112/M	3.6	700	0.75				
		22	DF132/MS	4.8	700	1.1				
		30	DF132/M	6.7	700	1.5				
		36	DF160/LM	10	720	2.2				
90JM/25/4-8/3/...	1440	24	DF112/M	3.6	700	0.75				
		30	DF132/MS	4.8	700	1.1				
		32	DF132/M	6.7	700	1.5				
90JM/25/4-8/6/...	1440	14	DF112/M	3.6	700	0.75				
		20	DF132/MS	4.8	700	1.1				
		26	DF132/M	6.7	700	1.5				
		32	DF160/LM	10	720	2.2				
90JM/25/4-8/9/...	1440	8	DF112/M	3.6	700	0.75				
		12	DF132/MS	4.8	700	1.1				
		18	DF132/M	6.7	700	1.5				
		24	DF160/LM	10	720	2.2				
		32	DF160/L	13.3	720	3				
100JM/25/4-8/3/...	1440	16	DF112/M	3.6	700	0.75				
		20	DF132/MS	4.8	700	1.1				
		26	DF132/M	6.7	700	1.5				
		32	DF160/LM	10	720	2.2				
100JM/25/4-8/6/...	1450	8	DF112/M	3.6	700	0.75				
		10	DF132/MS	4.8	700	1.1				
		16	DF132/M	6.7	700	1.5				
		24	DF160/LM	10	720	2.2				
		28	DF160/L	13.3	720	3				
100JM/25/4-8/9/...	1470	10	DF132/M	6.7	700	1.5				
		16	DF160/LM	10	720	2.2				
		22	DF160/L	13.3	720	3				
100JM/31/4-8/9/...	1470	10	DF132/M	6.7	700	1.5				
		16	DF160/LM	10	720	2.2				
		22	DF160/L	13.3	720	3				
		26	DF180/LM	16	720	3.7				
		30	DF180/L	20	720	4.5				

JM AEROFOIL - H.T. SERIES



Motor Frame Size Schedules:

H.T. 400/2: Two Speed (Full & Other P.A.M.Wound)

400 V / 50 Hz / 3 ϕ

Code	Speed rev/min	Max. Pitch Angle (°)	Motor	Motor Rating (kW)	Low Speed		Full Load Current (A)	Starting Current d.o.I (A)	Efficiency %	Power Factor cos ϕ
					rev/min	(kW)				
50JM/20/4-6/3/...	1420	30	D80/A	0.37	920	0.11	Information available on request			
		36	D80/B	0.5	920	0.15				
50JM/20/4-6/6/...	1420	20	D80/A	0.37	920	0.11				
		26	D80/B	0.5	920	0.15				
		32	D90/L	0.67	910	0.2				
		40	D90/L	0.9	910	0.27				
56JM/20/4-6/3/...	1420	22	D80/A	0.37	920	0.11				
		26	D80/B	0.5	920	0.15				
		32	D90/L	0.67	910	0.2				
		36	D90/L	0.9	910	0.27				
56JM/20/4-6/6/...	1420	12	D80/A	0.37	920	0.11				
		16	D80/B	0.5	920	0.15				
		22	D90/L	0.67	910	0.2				
		28	D90/L	0.9	910	0.27				
		40	D100/LA	2	940	0.6				
63JM/20/4-6/3/...	1420	8	D80/A	0.37	920	0.11				
		12	D80/B	0.5	920	0.15				
		18	D90/L	0.67	910	0.2				
		24	D90/L	0.9	910	0.27				
		36	D100/LA	2	940	0.6				
63JM/20/4-6/6/...	1420	10	D90/L	0.67	910	0.2				
		14	D90/L	0.9	910	0.27				
		30	D100/LA	2	940	0.6				
		36	D100/LA	2.65	940	0.9				
63JM/25/4-6/3/...	1440	32	DF112/M	3.7	960	1.25				
63JM/25/4-6/6/...	1440	36	DF112/M	3.7	960	1.25				
63JM/25/4-6/9/...	1440	40	DF112/M	3.7	960	1.25				
71JM/20/4-6/3/...	1440	8	D90/L	0.67	910	0.2				
		12	D90/L	0.9	910	0.27				
		28	D100/LA	2	940	0.6				
		34	D100/LA	2.65	940	0.9				
		36	DF112/M	3.7	960	1.25				
71JM/20/4-6/6/...	1440	18	D100/LA	2	940	0.6				
		22	D100/LA	2.65	940	0.9				
		30	DF112/M	3.7	960	1.25				
71JM/25/4-6/3/...	1440	32	DF112/M	3.7	960	1.25				
71JM/25/4-6/6/...	1440	36	DF112/M	3.7	960	1.25				
71JM/25/4-6/9/...	1440	28	DF112/M	3.7	960	1.25				
		36	DF132/MS	5	950	1.5				
80JM/25/4-6/3/...	1440	32	DF112/M	3.7	960	1.25				
80JM/25/4-6/6/...	1440	24	DF112/M	3.7	960	1.25				
		30	DF132/MS	5	950	1.5				
		36	DF132/M	6.7	950	2.1				
80JM/25/4-6/9/...	1440	18	DF112/M	3.7	960	1.25				
		24	DF132/MS	5	950	1.5				
		30	DF132/M	6.7	950	2.1				
		36	DF160/LM	10	970	3				

JM AEROFOIL - H.T. SERIES



Motor Frame Size Schedules: H.T. 400/2: Two Speed (Full & Other P.A.M. Wound)

400 V / 50 Hz / 3 ϕ

Code	Speed rev/min	Max. Pitch Angle (°)	Motor	Motor Rating (kW)	Low Speed		Full Load Current (A)	Starting Current d.o.l (A)	Efficiency %	Power Factor cos \emptyset
					rev/min	(kW)				
90JM/25/4-6/3/...	1440	24	DF112/M	3.7	960	1.25	Information available on request			
		30	DF132/MS	5	950	1.5				
		32	DF132/M	6.7	950	2.1				
90JM/25/4-6/6/...	1440	14	DF112/M	3.7	960	1.25				
		20	DF132/MS	5	950	1.5				
		26	DF132/M	6.7	950	2.1				
		32	DF160/LM	10	970	3				
90JM/25/4-6/9/...	1440	8	DF112/M	3.7	960	1.25				
		12	DF132/MS	5	950	1.5				
		18	DF132/M	6.7	950	2.1				
		26	DF160/LM	10	970	3				
		32	DF160/L	13.2	970	3.7				
100JM/25/4-6/3/...	1440	16	DF112/M	3.7	960	1.25				
		22	DF132/MS	5	950	1.5				
		26	DF132/M	6.7	950	2.1				
		32	DF160/LM	10	970	3				
100JM/25/4-6/6/...	1450	8	DF112/M	3.7	960	1.25				
		12	DF132/MS	5	950	1.5				
		16	DF132/M	6.7	950	2.1				
		24	DF160/LM	10	970	3				
		30	DF160/L	13.2	970	3.7				
100JM/25/4-6/9/...	1470	10	DF132/M	6.7	950	2.1				
		16	DF160/LM	10	970	3				
		22	DF160/L	13.2	970	3.7				
100JM/31/4-6/9/...	1470	10	DF132/M	6.7	950	2.1				
		16	DF160/LM	10	970	3				
		22	DF160/L	13.2	970	3.7				
		26	DF180/LM	16	980	5.3				
		28	DF180/L	18.5	980	6				

Dimensions and Weights

Long Cased

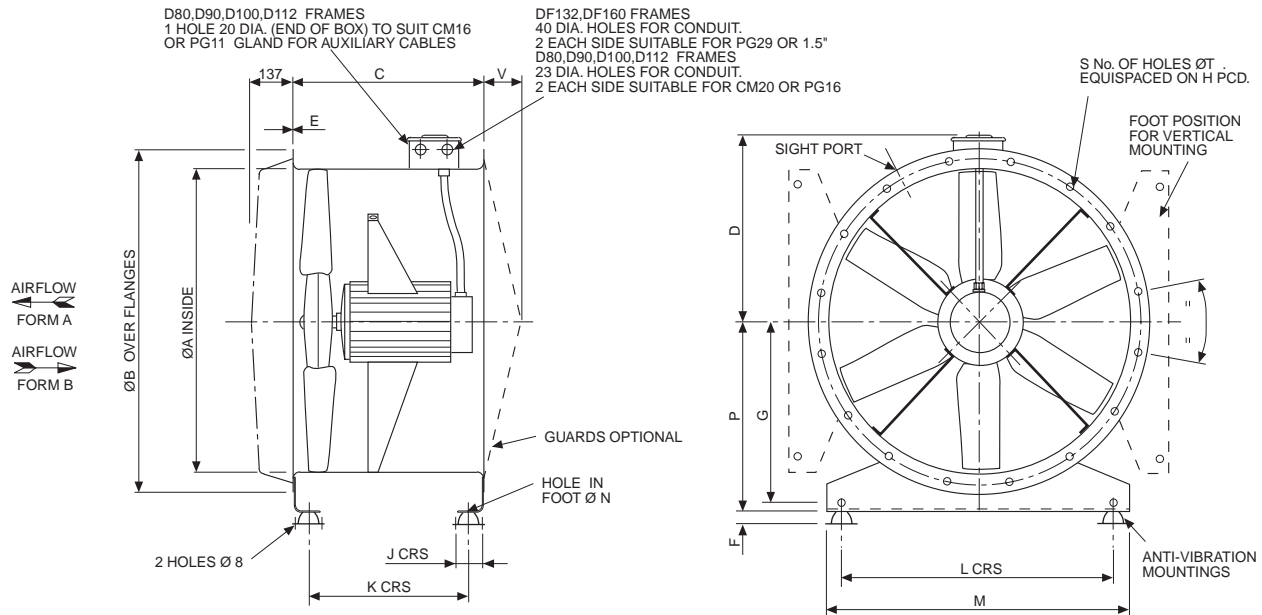

Code	Motor Frame	DIMENSION REFERENCE (mm)																		Weight (kg)
		A	B	C	D	E	F	G	H	J	K	L	M	N	P	S	T	V		
315	D80	315	395	375	235	2.5	25	25	175	355	66	289	265	315	10	200	8	10	30	31
	D90	450	530	375	306	3	25	255	500	66	289	400	450	10	280	8	12	30	36	
	D100	450	530	520	306	3	25	255	500	66	434	400	450	10	280	8	12	30	49	
	DF112	450	530	520	306	3	25	255	500	66	434	400	450	10	280	8	12	30	63	
450	D80	500	594	375	338	2.5	25	290	560	66	289	450	500	10	315	12	12	30	39	
	D90	500	594	520	338	3	25	290	560	66	434	450	500	10	315	12	12	30	59	
	D100	500	594	520	338	3	25	290	560	66	434	450	500	10	315	12	12	30	61	
	DF112	500	594	520	338	3	25	290	560	66	434	450	500	10	315	12	12	30	75	
500	D80	560	654	375	368	2.5	25	330	620	66	289	510	560	10	355	12	12	50	43	
	D90	560	654	520	368	3	25	330	620	66	434	510	560	10	355	12	12	50	61	
	D100	560	654	520	368	3	25	330	620	66	434	510	560	10	355	12	12	50	63	
	DF112	560	654	520	368	3	25	330	620	66	434	510	560	10	355	12	12	50	77	
630	D80	630	724	375	403	3	25	375	690	66	289	580	630	10	400	12	12	50	57	
	D90	630	724	520	403	3	25	375	690	66	434	580	630	10	400	12	12	50	75	
	D100	630	724	520	403	3	25	375	690	66	434	580	630	10	400	12	12	50	77	
	DF112	630	724	520	403	3	25	375	690	66	434	580	630	10	400	12	12	50	89	
	DF132	630	724	520	440	4	25	375	690	66	434	580	630	12	400	12	12	50	158	
	DF160	630	724	625	440	4	25	375	690	66	529	580	630	12	400	12	12	50	215	
710	D80	710	804	375	443	3	25	415	770	66	259	660	710	10	440	16	12	50	63	
	D90	710	804	520	443	3	25	415	770	66	404	660	710	10	440	16	12	50	79	
	D100	710	804	520	443	3	25	415	770	66	404	660	710	10	440	16	12	50	81	
	DF112	710	804	520	443	3	25	415	770	66	404	660	710	10	440	16	12	50	93	
	DF132	710	804	520	480	4	25	415	770	66	404	660	710	12	440	16	12	50	170	
800	D80	800	894	375	488	3	25	485	860	66	259	750	800	10	510	16	12	50	68	
	D90	800	894	520	488	3	25	485	860	66	404	750	800	10	510	16	12	50	88	
	D100	800	894	520	488	3	25	485	860	66	404	750	800	10	510	16	12	50	90	
	DF112	800	894	520	488	3	25	485	860	66	404	750	800	10	510	16	12	50	102	
	DF132	800	894	520	525	3	45	485	860	124	404	750	800	12	510	16	12	50	194	
900	DF160	800	894	625	525	5	45	485	860	124	499	750	800	12	510	16	12	50	229	
	DF112	900	1006	520	538	3	25	491	970	66	444	850	900	10	518	16	15	50	107	
	DF132	900	1006	520	575	5	45	491	970	124	444	850	900	12	518	16	15	50	214	
1000	DF160	900	1006	625	575	5	45	491	970	124	539	850	900	12	518	16	15	50	261	
	DF112	1000	1106	520	588	3	25	547	1070	66	444	950	1000	10	574	16	15	50	115	
	DF132	1000	1106	520	625	5	45	547	1070	124	444	950	1000	12	574	16	15	50	229	
DF160	1000	1106	625	625	5	45	547	1070	124	539	950	1000	12	574	16	15	50	277		

Ancillaries

Silencer - B Type

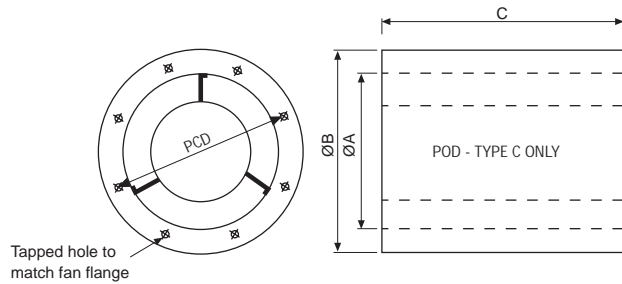

Suitable for fan ØA	B	C	Weight (kg)	
			B type	C type
315	415	315	10	13
355	455	355	12	15
400	500	400	15	18
450	600	450	20	24
500	650	500	25	29
560	710	560	30	35
630	780	630	35	42
710	860	710	44	53
800	1000	800	55	66
900	1100	900	70	84
1000	1200	1000	82	100

The above silencers give the approximate dB(A) reductions:-

B Type 1 diameter length - 7 to 10 dB(A)

C Type 1 diameter length - 12 to 15 dB(A)

For full acoustic details contact our Woods Acoustic Division. Tel: +44 (0) 1206 544122

Suitable for fan ØA	D	E	F	G	Weight (kg)		
					Matching Flange	Flexible Connection	Damper
315	32	110	225	-	1.1	3.3	8
355	32	110	225	-	1.3	3.9	9
400	32	110	225	17	1.5	4.5	10
450	32	110	225	39	1.7	5.0	12
500	32	110	225	75	2.0	5.5	16
560	32	110	225	125	2.3	6.8	18
630	50	160	225	176	3.0	7.5	20
710	50	160	225	210	3.2	8.1	23
800	50	160	225	270	3.6	9.1	27
900	50	160	225	305	4.1	10.4	31
1000	50	160	225	345	4.6	11.6	36
1120	51	165	400	225	5.2	12.9	150
1250	51	165	400	290	5.8	14.4	166

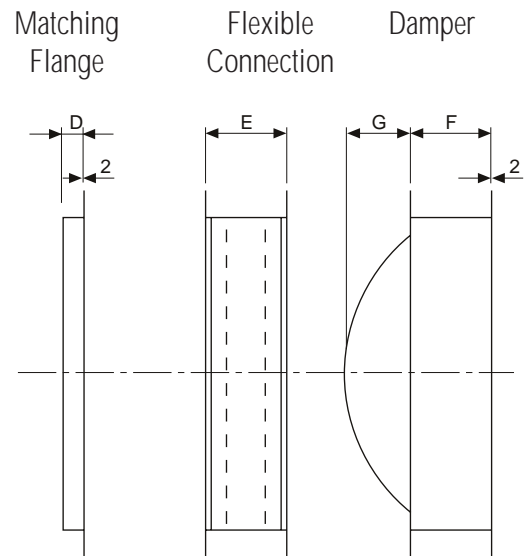

ANTI VIBRATION MOUNTINGS

Various types of anti vibration mountings can be specified against each H.T. temperature/time category on request.

All dimensions in mm and kgs

Ancillaries

Guards

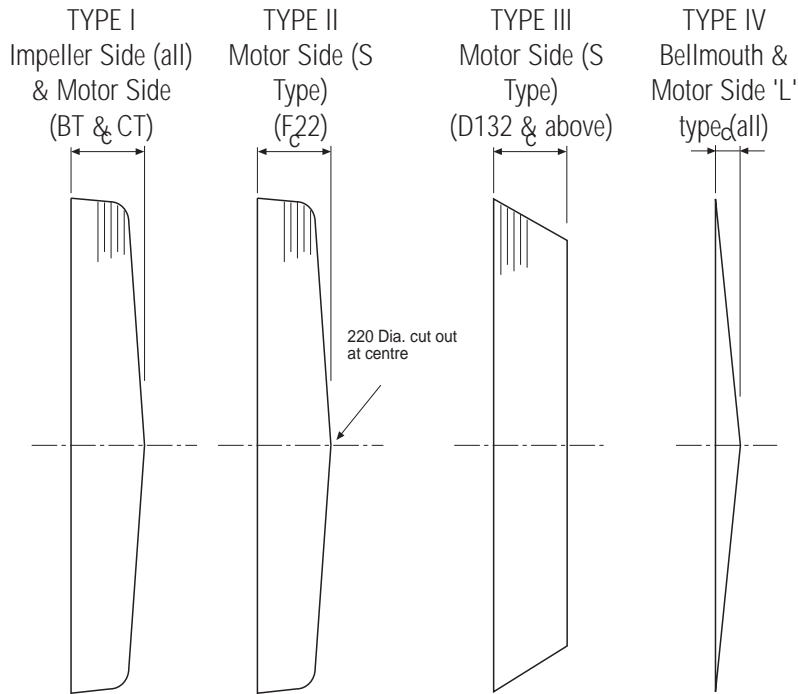

Suitable for fan	Type	C	Weight (kg)
315	I	137	1.2
315	IV	30	0.5
355	I	137	1.4
355	IV	30	0.5
400	I	137	1.6
400	IV	30	0.6
450	I	137	1.8
450	II	137	1.6
450	IV	30	0.6
500	I	137	2.0
500	II	137	1.8
500	IV	30	0.7
560	I	137	2.2
560	II	137	2.0
560	IV	50	1.0
630	I	137	2.8
630	II	137	2.6
630	III	350	3.0
630	IV	50	1.2
710	I	137	3.2
710	II	137	3.0
710	III	350	3.4
710	IV	50	1.4
800	I	137	3.5
800	II	137	3.3
800	III	350	3.9
800	IV	50	1.5
900	I	137	4.2
900	II	137	4.2
900	III	310	4.8
900	IV	50	1.7
1000	I	137	5.0
1000	II	137	4.8
1000	III	310	5.6
1000	IV	50	2.0

Bellmouth

Suitable for fan ØA	C	D	Weight (kg)
315	65	379	1.0
355	85	423	1.2
400	80	480	1.5
450	95	536	2.0
500	87	600	3.2
560	100	668	4.0
630	108	757	4.8
710	126	857	5.4
800	134	957	6.8
900	150	1077	8.0
1000	167	1199	17.8

